

EVOLUTION

FLIGHT DISPLAY

Evolution E5 Dual EFI Pilot Guide

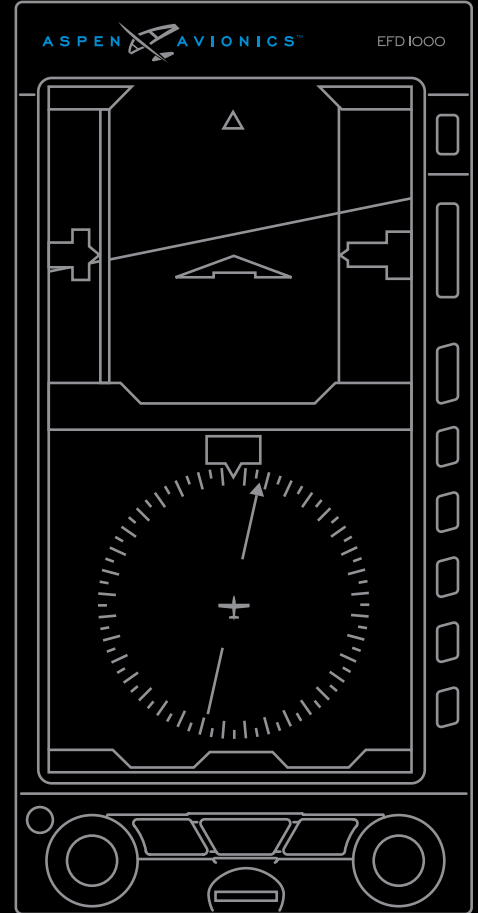

EVOLUTION

FLIGHT DISPLAY

Evolution E5 Dual EFI Pilot Guide

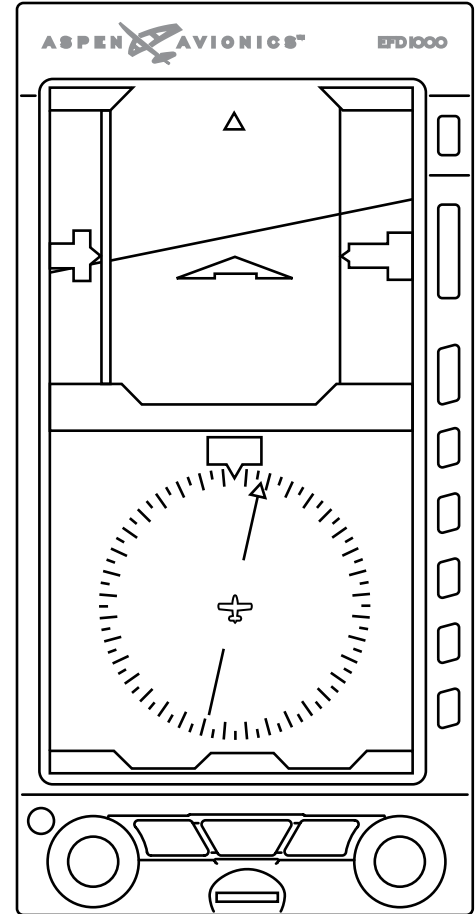

REVISION	DESCRIPTION of CHANGE
	Initial Release

Table of Contents

Document Revisions	iv
Copyrights, Trademarks and Patents	ix
Approvals	x
LIMITED WARRANTY Aspen Avionics, Inc.	xi
Conventions.....	xiv
Covered Functionality.....	xiv
Terminology	xiv
Color Philosophy.....	xvi
Warnings, Cautions, and Notes.....	xvii
Example Graphics.....	xviii
Pilot Familiarity.....	xviii
Information Covered in this Pilot's Guide	xix

Chapter 1

Welcome and Introduction..... 1-1

1.1. System Overview.....	1-3
1.1.1. Electronic Flight Instrument (EFI).....	1-4
1.1.2. Configuration Module (CM)	1-5
1.1.3. Analog Converter Unit (ACU) ¹	1-5

1.1.4. Remote Sensor Module (RSM).....	1-6
1.1.5. Evolution Databases.....	1-6

Chapter 2

Controls and Display 2-1

2.1. Controls & Display Orientation	2-2
2.2. Controls.....	2-4
2.2.1. Left and Right Knobs	2-4
2.2.1.1. Left Knob Functions	2-5
2.2.1.2. Right Knob Functions	2-5
2.2.1.3. SYNC Function.....	2-6
2.2.1.4. Using the Knobs (Example)	2-8
2.2.2. Navigation Source Select Buttons	2-8
2.2.3. Hot Keys.....	2-10
2.2.4. Menu.....	2-12
2.2.4.1. Using the Menus.....	2-12
2.2.4.2. Display Lighting	2-16
2.2.5. Range Buttons.....	2-17
2.2.6. REV Button.....	2-17

2.3. Display	2-18
2.3.1. Cleaning the Display Screen	2-19
2.3.2. Attitude Display	2-20
2.3.2.1. Attitude Director Indicator (ADI)	2-22
2.3.2.2. Airspeed Tape and Bug	2-23
2.3.2.3. Altitude Tape & Vertical Speed	2-24
2.3.3. Data Bar	2-25
2.3.4. Navigation Display	2-26
2.3.4.1. Numerical Direction Indicator (Magnetic Compass)	2-28
2.3.4.2. Course Pointer and Course Deviation Indicator (CDI) ¹	2-30
2.3.4.3. Deviation Off-Scale Indication	2-30
2.3.4.4. Auto Course Select	2-30
2.3.4.5. Rate of Turn Indicator	2-31
2.3.4.6. Vertical Speed Indicator (VSI)	2-32

Chapter 3

Flying the Dual EFI 3-1

3.1. Quick Controls Overview	3-3
3.2. Example Flight Scenario	3-5
3.2.1. Pre-Departure (Startup)	3-6
3.2.2. Departure	3-13

3.2.3. Enroute	3-15
3.3. Conclusion	3-17

Chapter 4

Reference Guide 4-1

4.1. Air Data, Attitude and Heading Reference System (ADAHRS)	4-2
4.1.1. Attitude	4-3
4.1.2. Pitot Obstruction Monitor	4-4
4.1.3. Heading	4-5
4.1.4. Free Gyro Mode	4-6
4.1.5. Degraded ADAHRS Performance	4-7
4.2. Attitude Display	4-8
4.2.1. Attitude Indicator	4-8
4.2.1.1. Roll Scale	4-9
4.2.1.2. Pitch Scale	4-9
4.2.1.3. Slip/Skid Indicator	4-9
4.2.2. Airspeed Indicator	4-10
4.2.2.1. Selected Airspeed	4-12
4.2.2.2. Airspeed Display	4-13
4.2.3. Altimeter	4-14
4.2.3.1. Barometric Units of Measure	4-15
4.2.3.2. Selected Altitude Field	4-17
4.2.3.3. Altitude Display	4-18

4.3. Data Bar	4-19
4.3.1. Ground Speed	4-19
4.3.2. Barometric Pressure Setting Display	4-19
4.4. Navigation Display	4-20
4.4.1. Compass	4-21
4.4.1.1. 360° Compass Mode	4-21
4.4.1.2. ARC Compass Mode	4-21
4.4.2. Course Pointer ¹	4-23
4.4.3. TO/FROM Indicator ¹	4-24
4.4.4. Course Deviation Indicator and Scale ¹	4-25
4.4.5. CDI Navigation Source	4-25
4.4.6. Auto Course	4-27
4.4.7. CDI Selected Course	4-28
4.4.8. Heading Bug	4-29
4.4.9. Aircraft Heading Display	4-30
4.4.10. Rate of Turn Indicator	4-30
4.4.11. Ground Track Marker	4-31
4.4.12. GPS OBS Operation with a EFI and a Mechanical Standby Nav Indicator	4-31
4.4.13. Course Pointer Operation with Integrated VOR/ Localizer/GPS Navigation Systems ¹	4-31
4.5. Vertical Speed Indicator	4-32
4.6. Autopilot Integration ¹	4-33
4.6.1. GPS Steering (GPSS) ¹	4-34
4.6.2. Typical Autopilot Operations ¹	4-38

Chapter 5

Customizing the EFI

5.1. Menu Overview	5-1
5.2. Configuring Vspeeds	5-5
5.3. LCD Brightness Control	5-10

Chapter 6

Expanded Emergency and Abnormal Procedures

6.1. Pitot/Static System Blockage	6-2
6.1.1. Identifying and Handling Suspected Pitot and/or Static System Failures	6-3
6.2. Frequent or Persistent CROSS CHECK ATTITUDE Annunciation	6-6
6.3. Difference Detected Between the E5 Dual EFI and Mechanical Attitude Indicators	6-6
6.4. Abnormal Shutdown Procedure	6-7
6.5. Loss of Aircraft Electrical Power	6-8
6.5.1. Overvoltage Protection	6-9
6.6. Power Override	6-11
6.7. In-Flight AHRS Reset	6-12

6.8. GPSS Operation, Annunciations, and Autopilot Modes.....	6-14
6.9. Warning, Caution, and Advisory Summary	6-18

Chapter 7

Appendices..... 7-1

7.1. Operating Limitations.....	7-1
7.2. Software Versions and Serial Number	7-1
7.3. Specifications.....	7-3
7.3.1. Primary Flight Display Unit (EFI)	7-3
7.3.2. Remote Sensor Module (RSM)	7-5
7.3.3. Analog Converter Unit (ACU)	7-5
7.3.4. Operational Specifications	7-6
7.4. Glossary	7-7
7.5. Index.....	7-10

Copyrights, Trademarks and Patents

Copyright 2007-2018.

Aspen Avionics® is a registered trademark of Aspen Avionics, Inc. Evolution™, EFD1000 Pro PFD™, EFD1000 MFD™, EFD500 MFD™, EFD1000™, EFD500™, EFD 1000 VFR, Evolution E5 Dual EFI and the Aspen Avionics logo are trademarks of Aspen Avionics, Inc. These trademarks may not be used without the express permission of Aspen Avionics, Inc. All rights reserved.

All other trademarks are the property of their respective companies. No part of the Pilot's Guide may be reproduced, copied, stored, transmitted, or disseminated, for any reason, without the express written permission of Aspen Avionics, Inc. Aspen Avionics hereby grants permission to download a single copy, and any revision, of the Pilot's Guide onto a hard drive or other electronic storage medium for personal use, provided that such electronic or printed copy of the Pilot's Guide or revision must contain the complete text of this copyright notice and provided further that any unauthorized commercial distribution of the Pilot's Guide or revision hereto is strictly prohibited.

Avidyne® is a registered trademark of Avidyne Corporation; Bendix/King® is a registered trademark of Honeywell; Garmin GTX™ is a trademark of Garmin International, Inc.; NavData® is a registered trademark of Jeppesen, Inc.; SkyWatch® is a registered trademark of L-3 Communications; Stormscope® WX-500 is a registered trademark of BFGoodrich Avionics Systems, Inc.; and XM is a registered trademark of XM Satellite Radio, Inc.

Approvals

The FAA has approved the Aspen E5 under STC SA10822SC. Installation of the E5 in a type-certificated airplane must be accomplished by a qualified person in accordance with this STC.

Aspen Avionics, Inc.
5001 Indian School Road NE
Albuquerque, NM 87110

Phone: (505) 856-5034
Fax: (505) 314-5440

www.aspenavionics.com

LIMITED WARRANTY

Aspen Avionics, Inc.

1. **YOUR WARRANTY.** Aspen Avionics, Inc. (“Aspen”) warrants to you, the original purchaser, that its Products (if purchased from an authorized dealer) will comply with applicable specifications (as set forth in the owner’s manual) in all material respects and will be free from material defects in workmanship or materials for a period of twenty-four (24) months beginning with the date that the aircraft in which the Product has been installed has been returned to service following installation by an Aspen authorized dealer (“Return to Service Date”). “Product” means new end equipment or hardware items, replaceable units and components of those units.
2. **YOUR REMEDY.** During the term of this warranty, Aspen will repair or replace, at its discretion, without charge (see Section 13 below for information on covered transportation costs), any Product that does not comply with the warranty of Section 1 above (a “Nonconforming Product”), so long as the warranty claim is timely submitted and the procedures in Section 14 (below) are followed. Aspen warrants repaired and/or replacement items only for the unexpired portion of the original warranty period, or, if the warranty has expired, for six months from Aspen’s shipment of the repaired or replacement Product.
3. **CONDITIONS TO COVERAGE.** Aspen’s obligation under this warranty is conditioned on your fulfillment of the obligation to:
 - A. Maintain records accurately reflecting operating time of and maintenance performed on the Product,
 - B. Furnish proof sufficient to establish that the item is a Nonconforming Product, and
 - C. Allow Aspen access to all relevant records in order to substantiate your warranty claim.
4. **EXCLUSIONS.** The following are not covered by (and are expressly excluded from) this warranty:
 - A. Normal wear and tear and the need for regular overhaul and maintenance,
 - B. Exposure of the Product to temperature, environmental, operating, or other conditions other than those prescribed in the owner’s manual,
 - C. Failure to install or operate the Product as prescribed in the owner’s manual or as Aspen otherwise directs,
 - D. Alterations or repairs made by anyone other than Aspen or its authorized service center,
 - E. Maintenance, repair, installation, handling, transportation, storage, operation (including, without limitation, operation of the product’s software or host medium), or use which is improper or otherwise does not comply with Aspen’s instructions as set forth in the owner’s manual,

- F. Accident, contamination, damage from a foreign object or weather conditions, abuse, misuse, neglect, or negligence,
- G. Exposure of the product or the product's host medium to any computer virus or other intentionally disruptive, destructive, or disabling computer code, and
- H. Any damage precipitated by failure of a product Aspen has supplied that is not under warranty or by any product supplied by someone else.

5. **INVALIDATION OF WARRANTY.** This warranty is void if the product is altered or repair is attempted or made by anyone other than Aspen or its authorized service center.

6. **WARRANTY CARD.** The Return to Service Date must be included in an accurately completed Aspen warranty application form submitted by the installing authorized dealer within 30 days of the Return to Service Date. The warranty application must be signed by the authorized repairman who certifies that the equipment has been safely and properly installed in accordance with all Aspen supplied technical information and in accordance with all applicable FAA procedures and requirements. The warranty application form must note the repairman's FAA certificate number to be valid. FAILURE TO COMPLETE AND RETURN THE WARRANTY CARD MAY RESULT IN DENIAL OF WARRANTY CLAIMS. MAKING CERTAIN THAT THE WARRANTY CARD IS COMPLETED, SIGNED, AND RETURNED IS YOUR RESPONSIBILITY.

7. **SOLE REMEDY.** Aspen's sole obligation, and your exclusive remedy under this warranty, is limited to either the repair or replacement, at Aspen's option, of any Nonconforming Product as provided herein.

8. **EXCLUSIVE WARRANTY.** THIS WARRANTY IS EXCLUSIVE AND IN LIEU OF ALL OTHER WARRANTIES. THE IMPLIED WARRANTY OF MERCHANTABILITY AND IMPLIED WARRANTY OF FITNESS FOR A PARTICULAR PURPOSE, AS WELL AS ALL OTHER IMPLIED WARRANTIES (STATUTORY OR OTHERWISE) EXPIRE AT THE END OF THE WARRANTY PERIOD PRESCRIBED IN SECTION 1.

Some States do not allow limitations on how long an implied warranty lasts, so the above limitation may not apply to you.

9. **INCIDENTAL DAMAGES.** ASPEN SHALL NOT UNDER ANY CIRCUMSTANCES BE LIABLE FOR ANY SPECIAL, DIRECT, INDIRECT, INCIDENTAL OR CONSEQUENTIAL LOSS OR DAMAGES OF ANY KIND (INCLUDING WITHOUT LIMITATION: DAMAGES FOR LOSS OF PROFITS, LOSS OF REVENUES, OR LOSS OF USE OR BUSINESS INTERRUPTION), EVEN IF ASPEN HAS BEEN ADVISED OF THE POSSIBILITY OR CERTAINTY OF THOSE DAMAGES OR IF ASPEN COULD HAVE REASONABLY FORESEEN THOSE DAMAGES.

Some states do not allow the exclusion of incidental or consequential damages, so the preceding limitations may not apply to you.

10. **LIMITATION OF LIABILITY.** ASPEN'S AGGREGATE LIABILITY HEREUNDER, WHETHER BASED UPON CONTRACT, TORT (INCLUDING NEGLIGENCE AND STRICT LIABILITY), INDEMNITY, OR OTHERWISE, WILL NOT EXCEED THE PRICE PAID BY YOU FOR THE WARRANTED PRODUCT. THE EXCLUSIONS OF TYPES OF DAMAGES CONTAINED HEREIN WILL BE DEEMED INDEPENDENT OF, AND WILL SURVIVE, ANY FAILURE OF THE ESSENTIAL PURPOSE OF ANY LIMITED REMEDY UNDER THE TERMS OF ANY AGREEMENT.

11. **EXTENSION OF WARRANTY.** No extension of this warranty will be binding upon Aspen unless set forth in writing and signed by Aspen's authorized representative.

12. **DEALER WARRANTIES.** Any express or implied warranty or remedy in addition to or different from those stated herein that is offered by a dealer ("Dealer Warranty") will be the sole responsibility of the dealer, who will be solely responsible for all liability, loss, cost, damage, or expense arising out of or in connection with any such Dealer Warranty. Although Aspen provides training and assistance to dealers, it cannot control the installation of its Products by its dealers, which are independent businesses not owned or controlled by Aspen.

13. **TRANSPORTATION COSTS.** Aspen will assume round trip transportation costs for a Product determined by Aspen to be a Nonconforming Product in an amount not to exceed normal (non express) shipping charges within the continental United States. You are responsible for all import/export fees, taxes, duties, customs, documentation fees, clearance fees, and similar fees and charges. You may contact Aspen to obtain a freight courier account number for prepaid shipping of the return. If Aspen subsequently determines that the Product is not a Nonconforming Product, that this warranty is inapplicable, that the Product is out of warranty, that the defect or malfunction is excluded from coverage, or that the warranty is invalid, Aspen will invoice you for repair or replacement costs and the shipping costs. Risk of loss or damage for any Product in transit will be borne by the party initiating the transportation.

14. **WARRANTY PROCEDURE.** If you require warranty service, you may contact your local Aspen Authorized Dealer or you may contact Aspen directly as described below. An original or copy of the sales receipt from the original Aspen Authorized dealer will be required to obtain any warranty service. You may contact Aspen for warranty service directly by calling Aspen Customer Service at (505) 856-5034; by writing to Aspen Customer Service Department, Aspen Avionics, Inc., 5001 Indian School Road NE, Albuquerque, New Mexico, 87110; or by visiting the Aspen Website at <http://www.aspenavionics.com>.

This warranty gives you specific legal rights, and you may also have other rights, which vary from State to State.

Conventions

The following conventions, functionality, terminology, color philosophy, and definitions are used in this manual and on the EFD1000 Dual EFI.

Covered Functionality

This guide covers all the functions available in the Evolution E5 Dual EFI.

Terminology

The term **“EFI”**, is used throughout this Pilot’s Guide and refers to the Evolution E5 Dual EFI.

Figure 1 shows a typical EFI display. This guide uses the terminology listed in **Table 1** when referring to specific parts of the EFI and **Chapter 4** provides an in-depth discussion and step-by-step instructions for all the available functionality.



Figure 1
EFD1000 Display, Knobs, Buttons, and Keys

Term	Example
1	Buttons REV Button, Range Buttons, MENU Button
2	Hot Keys / Menu Keys Five keys on the lower right of the display
3	Buttons CDI Navigation Source Select Button (Center Button)
4	Knobs Left (CRS) Knob, Right (HDG) Knob
5	Navigation Display
6	Data Bar
7	Airspeed, attitude, altitude display

Table 1
EFD1000 PFD Display, Knobs, Buttons, and Keys

Color Philosophy

Table 2 provides the general operational philosophy of color usage on the EFI display.

COLOR	PURPOSE	COLOR	PURPOSE
RED	Used to indicate flight envelope and system limits, and for warning annunciations that require immediate pilot recognition and which may require immediate pilot correction or compensatory action. Red is used to indicate Data Link Weather precipitation areas.	GREEN	Used for navigation information or mode data related to or provided by the navigation source currently selected for display on the Course Deviation Indicator (CDI) (i.e., navigation deviations, equipment operating state, waypoint information). Green is also used to indicate Data Link Weather precipitation areas and the status of user controls (i.e., ON, enabled, or active).
AMBER	Used to indicate abnormal information sources, and for caution information that requires immediate pilot awareness and for which subsequent pilot action may be required. Amber is used to indicate Data Link Weather precipitation areas.	WHITE	Used to show primary flight data (e.g., IAS, ALT, HDG), scales, and Menu items that are selectable for editing.
MAGENTA	Used for pilot-selectable references (bugs) enabled for editing, for depicting the active GPS navigation leg on a moving map display, and for depicting the flight director bar.	GRAY	Used to show supplemental flight data, and for Hot Key and Menu legends that are OFF, disabled, or inactive.
CYAN	Used to indicate editable values that are not currently selected for editing. CYAN is also used to display bearing pointers, proximity and other traffic icons, and GPS track marker.	BLUE	Used to indicate the sky and Data Link Weather precipitation areas.
		BROWN	Used to indicate the ground.

Table 2
Color Guide

Warnings, Cautions, and Notes

Where applicable warnings, cautions, and notes are used in this manual. Aspen Avionics uses the following icons and definitions (**Table 3**).



Icon	Definition
 Warning	Emphasizes a crucial operating or maintenance procedure, which, if not strictly observed, could result in injury to, or death of, personnel or long term health hazards. Indicates a hazard that may require immediate corrective action.
 Caution	Indicates an essential operating or maintenance procedure, which, if not strictly observed, could result in damage to, or destruction of, equipment. Indicates the possible need for future corrective action.
 Note	Highlights an important operating or maintenance procedure, condition, or statement. Safe operation.

Table 3
Warning, Caution, and Note

Example Graphics

The example graphics and screen shots used throughout this Pilot's Guide are provided for reference only and are taken from a simulated flight. They should not be used for actual flights.

Pilot Familiarity

While the E5 is reasonably intuitive and easy to use, some familiarity with E5 Dual Electronic Flight Instrument required. Aspen Avionics strongly recommends that new users get some dual instruction from an experienced instrument CFI, and spend some time becoming familiar with the E5 Dual EFI.

E5 Overview

The E5 system is built around the EFD 1000 which replaces the Attitude Indicator and Directional Gyro of your six primary flight instruments. The E5 Dual EFI is IFR capable with limitations.

E5 / MFD Compatibility

Aspen offers an MFD 500 and MFD 1000. The E5 is not compatible with our MFDs. In order to integrate with either MFD you must first upgrade the E5 to a PFD Pro.

Information Covered in this Pilot's Guide

This Pilot's Guide covers all the features and options available in the E5 Dual EFI.

E5 Dual EFI Options:

- ACU (Analog converter unit) used to connect auto pilots, analog nav sources, legacy GPS.

If there is a chance you may wish to upgrade to a Pro in the future including the optional ACU with the original E5 install is highly recommended. Including it in the initial install eliminates the need to open up the aircraft during a E5 to PRO upgrade.

If an ACU was part of the initial E5 installation the VFR to PRO upgrade is a simple software upgrade.

The E5 to PRO software upgrade converts the E5 CDI to a HSI in both 360 compass and arc modes, adds dual bearing pointers in 360 compass mode, vertical deviation indicator, localizer deviation indicator, minimums (decision height) flight director and Radio Altitude display input.

Chapter 1

Welcome and Introduction

Welcome to Aspen Avionics' Evolution Flight Display (EFD) System, the most flexible, expandable, and upgradable Electronic Flight Instrument available for general aviation aircraft. Designed to replace the attitude indicator and directional gyro. This modularity and upgradability allows the system to grow with you and your airplane, over time and affordably.

The EFD system is built around the E5 Dual EFI, which replaces a vertical pair of your six primary flight instruments. The E5 has a bright, high-resolution, six-inch diagonal LCD display, and a number of knobs, buttons, and keys the pilot uses to control the system. The three-inch diameter, four-inch deep can on the back of the display slides into existing panel cutouts (where the top mechanical instrument used to be) (**Figure 1-1**).



Figure 1-1
E5 Dual EFI Primary Flight Display Unit



Figure 1-2
Single Display E5 Dual EFI

The center of the EFD System is the E5 Dual EFI, which replaces the traditional mechanical Attitude Indicator (AI) and Directional Gyro (DG), Course Deviation Indicator or Horizontal Situation Indicator (HSI) (**Figure 1-2**).

NOTE

Please spend some time with your aircraft flight manual supplement and avionics installer to understand exactly how your E5 is installed and configured in your particular aircraft, to understand the features and capabilities available to you, and to understand how various aircraft system failures and abnormalities may affect your E5 display.

1.1. System Overview

The E5 system typically consists of four components:

1. E5 Display Unit (Dual EFI)
2. Configuration Module (CM)
3. Remote Sensor Module (RSM)
4. Analog Converter Unit (ACU)¹

The ACU converts older analog signals and interfaces to the industry-standard digital ARINC 429 interface, which is the native language of the E5 Dual EFI. In some installations, generally when the aircraft is not equipped with an autopilot and has only digital GPS/Nav/Comm, the ACU may be omitted.

The system architecture in **(Figure 1-5)** shows the relationships of the Dual EFI, RSM, CM and ACU.

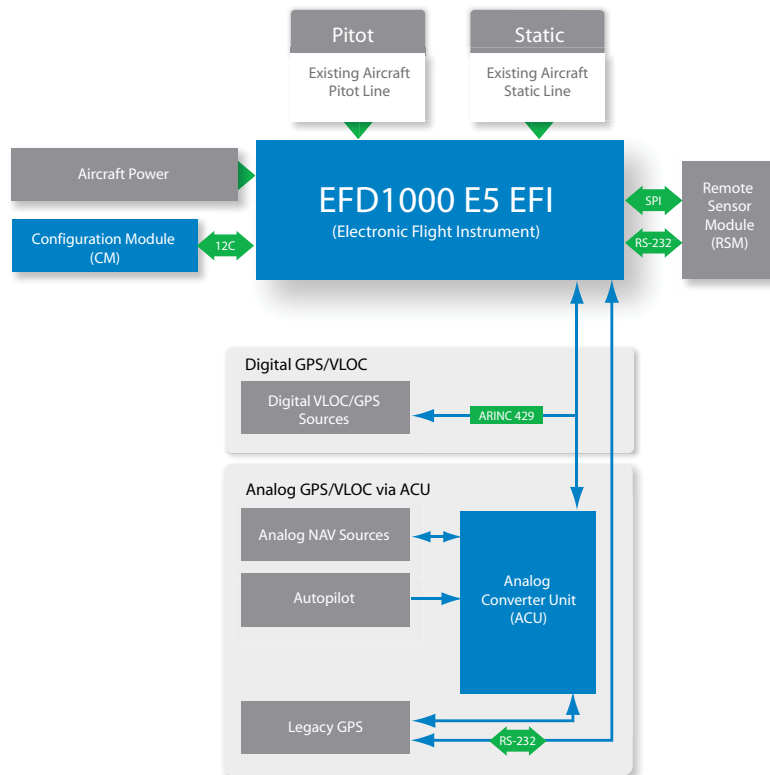

Figure 1-5
Dual EFI System Architecture

¹ E5 option

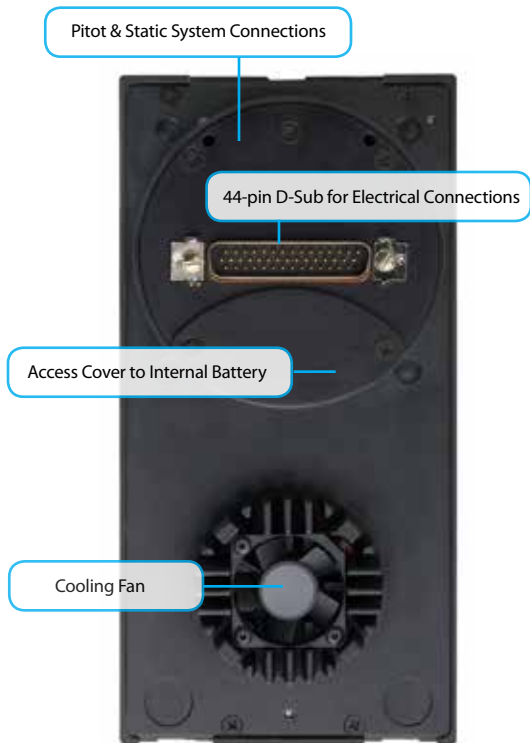

Figure 1-6
EFD1000 Display Unit
Rear Connections

1.1.1. E5 Dual EFI Unit

The E5 Dual EFI Unit is a digital system that consists of a high resolution, six-inch diagonal color LCD display, user controls, photocell, and micro SD data card slot. The three-inch diameter, four-inch deep can on the back of the display contains a non-removable electronics module that includes:

- A Sensor Board with solid-state Attitude and Heading Reference System (AHRS) and digital Air Data Computer (ADC)
- A Main Application Processor (MAP) board with Central Processing Unit (CPU), graphics processor and system memory
- An Input-Output Processor (IOP) board for integrating communications with other aircraft systems

Also on the rear of the unit (**Figure 1-6**) are:

- An access cover for removing and replacing the built-in backup battery
- Pneumatic connections to the aircraft's pitot and static systems
- 44-pin D-sub connector for electrical connections to the display
- A cooling fan, to cool the electronics and LCD backlights

The E5 mounts to the front surface of the instrument panel using the standard installation kit; an optional flush-mount installation kit is also available.

1.1.2. Configuration Module (CM)

The Configuration Module (**Figure 1-7**), contains an EEPROM device that retains system configuration and calibration data and provides two primary functions:

- Retains aircraft-specific configuration information, calibration data, and user settings, allowing the E5 to be swapped for service purposes without re-entering or re-calibrating the installation
- Contains a license key that configures the E5 software features

The CM is typically attached to the wire bundle coming out of the D-sub connector on the display unit.



Figure 1-7
Configuration Module (CM)

1.1.3. Analog Converter Unit (ACU)¹

The Analog Converter Unit (ACU) (**Figure 1-8**), is highly recommended if you are considering upgrading your E5 to a Pro PFD. If installed with the E5 it eliminates the need to open the aircraft during the E5 to Pro upgrade. It enables the all-digital, EFD1000 System to interface with analog avionics when required. The ACU converts multiple analog interfaces to the digital ARINC 429 buses supported by the E5. Control parameters, such as desired heading, are also sent from the EFI to the ACU for conversion to analog format for autopilot support. The ACU is required when any of the following capabilities are required in a EFI installation:

- Interface to supported autopilots
- Interface to conventional VHF navigation radios
- Interface to legacy (non-ARINC 429) GPS navigators

If ARINC 429-based digital radios, such as the Garmin 400/500-series GPS/nav/comm radios are installed in the aircraft and no other aircraft interfaces are desired, the ACU is not required.



Figure 1-8
Analog Converter Unit (ACU)

1. E5 Dual EFI Unit option



Figure 1-9
Remote Sensor Module (RSM)

1.1.4. Remote Sensor Module (RSM)

The Remote Sensor Module (RSM) (**Figure 1-9**), is an integral part of the EFI system and works together with the display unit sensors as part of the AHRS and ADC. The RSM looks and mounts like a GPS antenna and is mounted on the exterior of the fuselage, typically aft of the cabin.

The RSM contains the following sub-systems:

- 3D magnetic flux (heading) sensors

The RSM communicates with the EFI via a digital cable connection.

1.1.5. Evolution Databases

The E5 Dual EFI doesn't require a data base.

Chapter 2

Controls and Display

The E5 Dual EFI is a flat-panel LCD primary flight instrument that presents the pilot with all of the information from the traditional six-pack of mechanical instruments: Airspeed, Attitude, Altitude, Turn Coordinator, Heading Indicator and Vertical Speed Indicator (VSI). Modern technology and standard EFIS symbology enable the consolidation of all six instruments into a single display, tightening the pilot's instrument scan and reducing pilot workload.

The E5 is a single vertical instrument that replaces the existing Attitude Indicator and Heading Indicator. The display is divided into three parts: an upper Attitude Display, a lower Navigation Display, and a Data Bar between the upper and lower halves.

This chapter gives an overview of all the instruments, information, and controls of the EFI. **Table 2-1** and **Figure 2-2** identify the controls and display orientation (see **Chapter 4, Reference Guide** for more details).



Figure 2-1
E5 Dual EFI



Figure 2-1a
E5 Dual EFI

2.1. Controls & Display Orientation

CONTROLS		ATTITUDE DISPLAY	
1	Power Button	16	Attitude Display
2	No Function	17	Aircraft Reference Symbol
3	Menu Button	18	Roll Pointer
4	No Function	19	Slip/Skid Indicator
5	No Function	20	Altitude Tape
6	360/ARC View	21	Selected Altitude Field (controls the Altitude Bug)
7	GPSS - GPS Steering ¹ On/Off	22	Numerical Altitude Indication, Altitude Drum/Pointer
8	BARO	23	Altitude Bug
9	Right Knob, HDG, altitude bug	24	Airspeed Tape
10	No Function	25	Selected Airspeed Field (controls the Airspeed Bug)
11	CDI Navigation Source Select Button (Middle Button)	26	Airspeed Bug
12	No Function	27	Numerical Airspeed Indicator, Airspeed Drum/Pointer
13	Left Knob, course and air speed bug		
14	Automatic Dimming Photocell		
15	microSD Card Slot		

DATA BAR	
28	Barometric Pressure Setting Field
29	Ground Speed
NAVIGATION DISPLAY	
30	Navigation Display
31	Owship Symbol
32	Course Pointer
33	Rate of Turn Indicator
34	Ground Track Marker
35	Numerical Direction Indicator
36	Selected Course (CRS) Field
37	Selected Heading Field
38	Heading Bug
39	Vertical Speed Numerical Value

40	Vertical Speed Tape
41	Selected CDI Navigation Source
42	Left Knob State
43	Right Knob State
44	Hot Key Label
45	CDI TO/FROM/LOC Indicator
46	Course Deviation Indicator
47	Lateral Deviation Indicator (LDI)
48	Vertical Deviation Indicator (VDI)

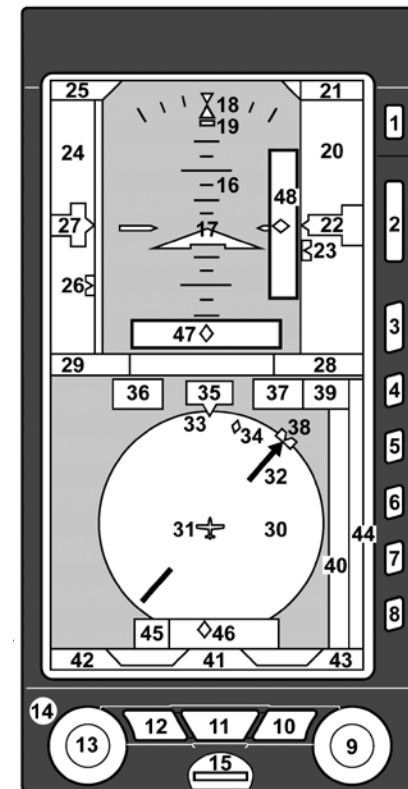

Figure 2-2
E5 Dual EFI Display Elements

Table 2-1
EFI Display Elements

1. With compatible autopilots

2.2. Controls

The primary means for the pilot to control the EFI are the two knobs and center button at the bottom of the display. The knobs control setting CRS and HDG, and additional bugs and altitude settings. The lower center button control selection of navigation sources for the CDI. There are center button controls above the Hot Keys to control entering and exiting the Menu and Reversion or Manual Power Control.

Five Hot Keys to the right of the Navigation Display toggle various features on and off. The function of each is indicated by the label on the display to the left of each key.

2.2.1. Left and Right Knobs

The Left and Right Knobs are designed to provide immediate operation yet minimize the possibility of an inadvertent operation. This is accomplished by requiring that the first action of the knob “wakes up” the knob and changes the label from cyan to magenta. The first click when the knob is turned or the first press on the knob, “wakes up” the knob function.

Press the knob more than once to cycle through its Menu options in a round-robin sequence or press and hold the knob to synchronize (SYNC) the function's value (**see Section 2.2.1.3. SYNC Function**). After 10 seconds of inactivity, the knob returns to its default setting.

2.2.1.1. Left Knob Functions

The Left Knob is used to set the Course (CRS) and Airspeed Bug (IAS). Course (CRS) is the default setting for the Left Knob.

Refer to **Table 2-1** and **Figure 2-2**

- Rotate the Left Knob one click or Press the knob once to set the course (CRS) (**Refs. 32 and 36** and see **NOTE** about Auto Course)
- Press the Left Knob twice to set the Airspeed Bug (IAS) and Selected Airspeed Field (**Refs. 25 and 26**)

2.2.1.2. Right Knob Functions

The Right Knob is used to set Heading (HDG), Selected Altitude Field (ALT), Barometric Pressure (BARO). Successive presses of the Right Knob will cycle through HDG and ALT in a round-robin sequence. Rotate the Right Knob to the left or right to decrease or increase the value of selected field. Heading (HDG) is the default setting for the Right Knob.

Refer to **Table 2-1** and **Figure 2-2**

- Rotate the Right Knob one click or Press the knob once to set the Selected Heading Field/Heading Bug (HDG) (**Refs. 37 and 38**)
- Press the Right Knob twice to set the Selected Altitude Field (ALT)/Altitude Bug (**Refs. 21 and 23**)



NOTE

*When the CDI navigation source is selected to a GPS receiver and the Auto Course is enabled in the Menu, the course is set automatically by the GPS and is not pilot-adjustable (see **Section 4.4.6**). This state is indicated by the CRS field and Knob label shown in green with an inverse "A". In this case, pressing the Left Knob will enable you to set only the Airspeed Bug (IAS).*



Figure 2-3
Left and Right Knobs and Corresponding Fields

2.2.1.3. SYNC Function

Knob SYNC Function

1. Press the Knob until its state shows the value you want to set in magenta.
2. Press and hold the Knob for approximately one (1) second to SYNC the field's value according to the rules shown in **Table 2-2**.
3. After 10 seconds of inaction, the knob reverts to its home state (CRS or HDG), and the labels and field turn to cyan (inactive).

Right Knob		
	SYNC Action	
1	ALT	Altitude Bug is set to the current altitude.
2	BARO	Set to 29.92 in Hg or 1013 mB.
3	HDG	Set to the current heading.
4	Right Knob -Current State default setting: HDG Cyan indicates field is inactive.	
5	IAS	Set to the current indicated airspeed.

Left Knob		
	SYNC Action	
6	CRS	VOR navigation Course Pointer points to the VOR. CRS value is the reciprocal of the current VOR radial. The deviation bar centers with a "TO" indication.
		GPS Course Pointer points to the active GPS waypoint. The deviation bar centers with a "TO" indication. (AUTOCRS must be disabled).
		GPS AUTOCRS enabled No effect.
7	Left Knob - Current State default setting: CRS Cyan indicates field is inactive.	

Table 2-2
Left and Right Knob SYNC Description



Figure 2-4
Editing the HDG field



Figure 2-5
HDG field updated and inactive

2.2.1.4. Using the Knobs (Example)

How to Set the Heading Bug (HDG)

1. Rotate the Right Knob to the desired heading value, shown both by the position of the Heading Bug and the numeric value in the Selected Heading Field (**Figure 2-4**). The HDG label, Heading Bug and the Selected Heading Field appears in magenta
2. After 10 seconds of inactivity, the knob defaults to HDG. The HDG label, Heading Bug and Selected Heading Field value will appear in cyan (**Figure 2-5**).

2.2.2. Navigation Source Select Buttons

The center button on the bottom of the display (**Figure 2-6**) allow the pilot to select the navigation source for the CDI (see **Section 4.4.5. CDI Navigation Source** for more detailed information).

The CDI Nav Source Select Button is the center button (**Figure 2-6**). It selects which of the available navigation sources will couple to the CDI, which in turn couples to the autopilot (if available). Each press of the CDI Nav Source Button selects the next available nav source, cycling through all available sources in a round-robin sequence. The currently coupled CDI nav source is displayed directly above the CDI Nav Source Select Button.

The available navigation sources are configured when the EFI was installed (depending on what is installed in the aircraft and connected to the EFI). The available navigation source choices are: GPS1 and VLOC1.

If a navigation source is configured to be available, but is not providing valid navigation data, its navigation source annunciation will be shown with a red slash through it, and the CDI will not be shown with the Deviation Indication. The pilot is able to select the invalid source, but no navigation data is provided.

The center button on the bottom of the display (**Figure 2-6**) allows the pilot to select the navigation source for the CDI (see **Section 4.4.5. CDI Navigation Source** for more detailed information).

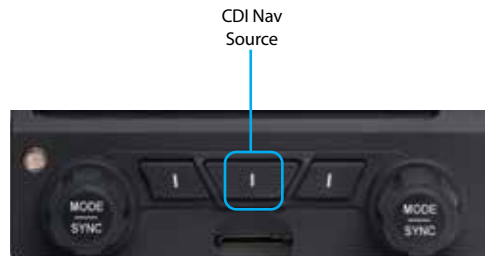

Figure 2-6
CDI Source Select Buttons

NOTE

When GPS is selected as the CDI's nav source, but no active waypoint is programmed in the GPS navigator, that source will be shown as invalid until an active flight plan or direct-to waypoint is programmed into the GPS.

For example, with a Garmin GNS-430 installed as the #1 navigation source, when "GPS" is shown immediately above the CDI Button on the GNS-430, the EFI will show GPS1 as an available, but invalid, nav source. When the pilot presses the CDI Button on the GNS-430 so that VLOC is now displayed on the GNS-430, the EFI will show VLOC1 as the available nav source, and GPS1 cannot be selected.

2.2.3. Hot Keys

The five keys along the lower right side of the EFI function as either single-action Hot Keys for frequently used commands or as Menu Keys when the Menu has been activated. The Hot Key functions are accessible at any time, except when the Menu is active.

Each Hot Key provides instant access to the assigned command. Each press of a Hot Key toggles between the settings that each key controls (see **Table 2-3**).

The Hot Key labels use the following color philosophy (see **Figure 2-7**).

- A green label and dark blue letters (also known as inverse green) indicates that the Hot Key function is enabled
- A dark blue label and green letters indicates that the Hot Key function is disabled
- A dark blue label and gray letters indicates that the Hot Key function is not available
- A dark blue label without letters indicates that the Hot Key has no function

The 360/ARC Hot Key labels indicate which mode is currently active on the Navigation Display.

HOT KEY		DESCRIPTION	OPTIONS	
1		No Function		
2		No Function		
3	360°/ ARC	Toggles between 360° and ARC modes of Navigation Display (see Section 4.4.1.)	360	360° Compass Mode
			ARC	ARC Compass Mode
4	GPSS	Toggles between GPS Steering (GPSS) Mode and HDG mode for Autopilot	GPSS	GPSS on
			GPSS	GPSS Off, HDG mode active
5	BARO	Toggles between BARO adjustment on or off for Barometric Pressure setting	BARO	BARO adjustment on
			BARO	BARO adjustment off

Table 2-3
Hot Key Descriptions

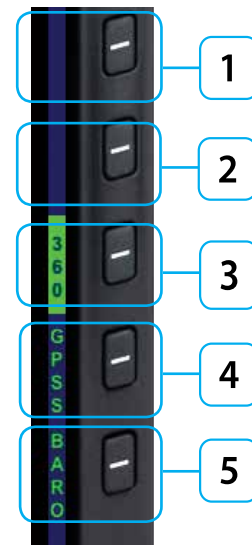

Figure 2-7
Hot Key Menu



Figure 2-8
Menu Navigation Mode

2.2.4. Menu

The MENU button is used to access the E5 Dual EFI's Menu to change options, and also to change the display brightness.

2.2.4.1. Using the Menus

Press the MENU button to activate the Menu (**Ref. 3**). The current menu page name is shown on the bottom center of the Navigation Display. Directly below the menu page name is a segmented menu page bar, giving a graphical representation of the current page relative to the total number of menu pages. The current menu page number is shown in the lower right corner of the Navigation Display.

Menu Page 1, General Settings is the one most commonly used in flight. It allows the pilot to enable or disable airspeed and altitude tapes, BARO, GPS Autocourse and conduct AHRS resets. The other menu pages are used for Vspeeds and map customization, EFI power management, product version information, and information and option settings, relative to your specific equipment and installed options.

The Menu operates either in the Navigation or Edit mode, as indicated by the label directly above the Right Knob. When the MENU button is first pressed, the Main Menu is in the Navigation mode, indicated by the magenta label SEL PAGE directly above the Right Knob (**Figure 2-8**). When in the Navigation mode, rotating the Right Knob navigates through the menu pages. Rotate the Right Knob clockwise to advance to the next menu page, counterclockwise to return to the previous page.

Each Menu Page has up to five selectable options, each adjacent to one of the five Hot Keys which double as Menu Keys when the Menu is active (**Item 1** of **Figure 2-9**

and **Table 2-4**). After navigating to the Menu Page containing the option you want to change, press the Menu Key adjacent to that option label, which initiates the Menu's Edit mode. When the Menu is in the Edit mode, the label, EDIT VALUE, is shown above the Right Knob in magenta (**Figure 2-10**), and the label of the item selected for editing is also shown in magenta. Rotate the Right Knob to change the value of the selected item. When finished, either select another displayed Menu option to change, or press the Right Knob to exit the Edit mode and return to Navigation mode to select another Menu Page.

When you are finished changing Menu options, press the MENU Button to exit.

- 1 Menu Options
- 2 Menu Page number and mode (Navigation mode shown)
- 3 Menu Page Name
- 4 Menu Page graphical bar
- 5 Brightness Control (see **Section 2.2.4.2.**)

Table 2-4
Menu



Figure 2-9
Main Menu



Figure 2-10
Menu Edit Mode

TPS: ENABLE

Figure 2-11
Menu Text - Editable

TPS: ENABLE

Figure 2-12
Menu Text - Enabled for Editing

EXT PWR: 21.1V

Figure 2-13
Menu Text - Status Only

Vle: 129

Figure 2-14
Menu Text - Disabled



Figure 2-15
Menu Display

The MENU text will display in one of the four colors listed and described in **Table 2-4**.

DISPLAY TEXT	DESCRIPTION	DISPLAY
WHITE	Editable option	Figure 2-11
MAGENTA	Editable option enabled	Figure 2-12
GREEN	Status Only	Figure 2-13
GRAY	Disabled (Not available for selection or editing)	Figure 2-14

Table 2-4
Menu Text



NOTE

These steps are provided as a basic overview. Each menu command is covered in detail in Chapter 5.

Access To and Navigation Within the Menu

1. Press the MENU button. The Menu displays on the Navigation Display adjacent to the Hot Keys (**Figure 2-15**).
2. Rotate the Right Knob to navigate through the different pages of the Menu. Rotating the Right Knob clockwise advances the Menu Pages, counterclockwise returns to previous pages.
3. Press the MENU Button to exit.

Edit Main Menu Items

1. Press the MENU Button.
2. Navigate to the desired Menu Page.
3. Press the Menu Key of the desired option. The Menu label turns magenta, and the EDIT VALUE label displays above the Right Knob (**Figure 2-16**).
4. Rotate the Right Knob to the desired value.
5. Press the Right Knob to return to Menu navigation mode.
6. Press the MENU Button to exit.

NOTE

Upon reaching the end of a list of editable menu options, continued rotation of the knob will not result in the continuous wrapping through the available editable menu options. Spinning the knob fully clockwise will go to the last menu page, while spinning the knob fully counterclockwise will go to the first menu page.

NOTE

Pressing the Right Knob returns to Navigation mode and allows selection of other menu options on different pages. Pressing another menu key on the current menu page saves any changes made and activates the newly selected option for editing.



Figure 2-16
EDIT VALUE Displays Above Right Knob



Figure 2-17
Display Brightness in BRT AUTO Mode



Figure 2-18
Display Brightness in BRT ADJUST Mode

2.2.4.2. Display Lighting

When the MENU button is pressed and the Menu is active, the Left Knob can be used to adjust the EFI display brightness.

By default, the LCD brightness operates in AUTO mode, and is adjusted based on photocell sensing of ambient lighting conditions. When the MENU is active and the LCD is in the BRT AUTO mode, the word, "AUTO", and a brightness level of 1-100 will be displayed in green above the Left Knob (**Figure 2-17**).

To override the AUTO brightness setting, press the Left Knob once to switch to the BRT ADJUST mode, and then rotate the Left Knob to set the brightness to the desired level (**Figure 2-18**). To return to AUTO brightness control, press the Left Knob again.

LCD MODE	DESCRIPTION	DISPLAY
Automatic BRT AUTO	LCD backlight intensity is automatically adjusted based on the ambient lighting conditions sensed by the Automatic Dimming Photocell. The maximum intensity in AUTO mode is 70%.	Figure 2-17
Manual BRT ADJUST	Allows the pilot to adjust the EFI display brightness from 1-100%	Figure 2-18

Table 2-5
Brightness Control

NOTE

The BRT AUTO display brightness level is determined by the amount of light detected by the photocell on the front of the display. If a light is used to illuminate the instrument panel, the photocell will respond, resulting in a bright display. When this happens, use the manual BRT ADJUST mode to reduce the brightness.

2.2.5. Range Buttons

Range Buttons have no function on the EFI.

2.2.6. REV Button

The red REV Button on the EFI can be used to override automatic power control in abnormal or emergency situations (see **Chapter 6, Section 6.4.** and **Figure 6-29** for more details).



Figure 2-19
EFI Display Areas

2.3. Display

The EFI replaces the existing Attitude Indicator and DG in the center of the primary flight instrument cluster. Like the instruments it replaces, the top half presents an Attitude Display and the bottom half contains a Navigation Display (**Figure 2-19**). Between the two halves is the Data Bar. The Data Bar contains a dedicated display of GPS Ground Speed (GS) and current BARO setting.

- 1 Attitude Display
- 2 Data Bar
- 3 Navigation Display

Unlike the mechanical indicators it typically replaces, EFI can also display all the data provided by the remaining four instruments in the six pack (airspeed, altitude, turn and slip, and vertical speed). Concentrating all primary flight information onto a single instrument directly in front of the pilot improves instrument scan and reduces pilot workload, thereby enhancing safety, especially in busy phases of flight.

The E5 Dual EFI generally follows standard display conventions for Electronic Flight Instrument Systems (EFIS), so a pilot with some experience and familiarity with other EFIS displays will usually transition quickly to using the EFD1000. Pilots for whom the E5 Dual EFI is their first real exposure to EFIS and glass cockpit flying, however, should get some transition training from a certified flight instructor (CFI) with EFIS experience. Pilots are also encouraged to study some of the excellent publications and training videos now available to help with the transition.

This section gives an overview of the main display elements and features. (see **Chapter 4, Reference Guide** for more details).

2.3.1. Cleaning the Display Screen

The Display Unit has an LCD screen that is prone to damage from scratches, smudging, and clouding caused by the use of improper cleaning agents and abrasive cloths. Exercise care when cleaning, using the following tips:

- Only clean the display when the it is off.
- Use a clean, soft, lint-free cloth dampened with a 50/50 solution of isopropyl alcohol and water, a pre-moistened lens cleaning tissue, such as Bausch & Lomb Sight Savers®, or a cleaning solution made especially for LCD displays.
- Never spray any cleaning solutions directly onto the screen; spray it into the cleaning cloth.
- Gently wipe the screen in a circular motion. Do not press hard on the screen.
- Remove all excess moisture to prevent damage to the display.
- The display should be dry before turning on the EFI.



CAUTION

Use caution when using isopropyl alcohol as it is flammable. Using any other chemicals or materials voids the warranty.

2.3.2. Attitude Display

The Attitude Display includes an Attitude Director Indicator (ADI), an Airspeed tape, an Altimeter tape, and approach course and glide slope indicators (**Table 2-6** and **Figure 2-20**), (see **Chapter 4, Reference Guide** for more details).

The Airspeed and Altitude tapes are the most obvious differences from a mechanical ADI. These tapes are common on most EFIS displays and will be immediately familiar to pilots with EFIS experience. Pilots without prior EFIS experience may need some training and experience to become to get comfortable with the Airspeed and Altimeter tapes as their primary references.

Transitioning pilots can use either their familiar mechanical instruments or the EFI tapes for airspeed and altitude references. Many pilots new to EFIS quickly find themselves relying on the tapes within a flight or two. Should the tapes prove distracting, the pilot can remove them from the display by disabling them in the Menu. (Page 1, GENERAL SETTINGS.

ATTITUDE DISPLAY	
16	Attitude Display
17	Aircraft Reference Symbol
18	Roll Pointer
19	Slip/Skid Indicator
20	Altitude Tape
21	Selected Altitude Field
22	Numerical Altitude Value, Altitude Drum/Pointer
23	Altitude Bug
24	Airspeed Tape
25	Selected Airspeed Field
26	Airspeed Bug
27	Numerical Airspeed Value, Airspeed Drum/Pointer

Table 2-6
Attitude Display Components

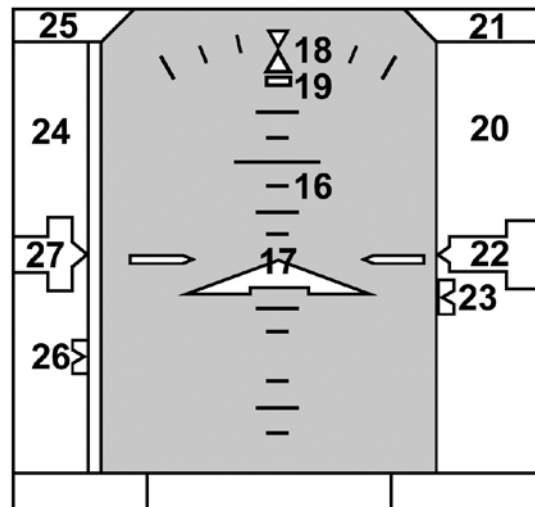

Figure 2-20
Attitude Display Components



Figure 2-21
Slip/Skid

2.3.2.1. Attitude Indicator (AI)

The Attitude Indicator (AI) features a conventional blue (sky) over brown (ground) background, with a white horizon line dividing the two areas. A triangular Aircraft Reference Symbol (**Ref. 17**) is in a fixed position and shows aircraft attitude relative to the horizon.

The pitch scale (or ladder) indicates degrees of nose up (blue) or nose down (brown) pitch relative to the apex of the aircraft symbol. Minor pitch marks are shown every 2.5° up to +/-20° of pitch, with major pitch marks every 10° up to +/-90° of pitch. The distance between pitch marks is greater than on most mechanical attitude indicators, making it easier for the pilot to fly more precise pitch attitudes.

At extreme pitch attitudes (above 30° nose up or below 25° nose down), red Unusual Attitude Recovery chevrons come into view, pointing towards the horizon or ground as applicable (see **Chapter 4, Section 4.2.1.2. Pitch Scale**). At extreme pitch attitudes, some sky (blue) or ground (brown) will always be displayed to help maintain situational awareness, even though the horizon line may be off-scale.

At the top of the AI are the roll scale, roll pointer, and slip/skid indicator (**Figure 2-21**). The roll scale is indicated by tick marks at 10°, 20°, 30°, 45°, and 60° on both sides of the zero roll inverted solid white triangle. The 45° marks are represented as hollow triangles.

Slip/skid is indicated by the lateral position of the white rectangle under the roll pointer. One rectangle width is equivalent to one ball width of a conventional inclinometer.

2.3.2.2. Airspeed Tape and Bug

Airspeed is indicated by a moving airspeed tape against a fixed position airspeed pointer, shown on the left-hand side of the Attitude Display (**Figure 2-22**). A numerical, rolling drum readout indicating airspeed values to the closest one knot or mile per hour is provided adjacent to the fixed pointer. Tick marks are provided on the airspeed tape every 10 knots (or mph, if so configured). Airspeeds between 20 kts (23 mph) to 450 kts (518 mph) are displayed. Outside of this range, the airspeed value is dashed.

Color speed bands are displayed on the indicated airspeed tape, corresponding to the color arcs found on a mechanical airspeed indicator.

Color speed markers are also displayed on the indicated airspeed tape, corresponding to the markers found on traditional airspeed indicators. All aircraft have a red line for aircraft never-exceed speed (V_{ne}). If the aircraft manufacturer has published an initial flap extension speed, a white triangle will be presented on the airspeed tape at this speed.

Textual V_{speed} markers can also be shown on the airspeed tape (e.g., V_x , V_y , V_a , etc.). These are typically programmed at installation, and (if left unlocked during installation) may also be adjusted by the pilot. V_{speed} display can be enabled or disabled by the pilot from Page 1 of the Menu (see **Chapter 5**).

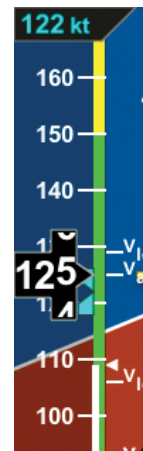

Figure 2-22
Airspeed Tape



Figure 2-23
Altitude Tape

The pilot can set a target airspeed using the Left Knob (see **Section 4.2.2.1**). The target airspeed is shown on the Airspeed Tape as an Airspeed Bug with its setting displayed numerically above the Airspeed Tape. The Airspeed Bug and numerical value are for visual reference only, to help the pilot maintain a target airspeed; there is no alerting for deviations from the target.

2.3.2.3. Altitude Tape

Altitude is indicated by a moving altitude tape against a fixed position altitude pointer (**Figure 2-2, No. 20, 22**), shown on the right-hand side of the Attitude Display (**Figure 2-23**). A numerical rolling drum readout indicating altitude values to the closest 20 feet is provided adjacent to the fixed pointer.

Minor tick marks are provided on the tape at 20-foot intervals, and major tick marks are provided at 100-foot intervals. The thousand and ten-thousand digits are larger than other digits on the tape. Negative altitudes are indicated by a “-” sign preceding the numerical altitude value in the drum.

The current altimeter barometric pressure setting is shown just below the Altitude tape in the Data Bar (**Figure 2-2, No. 28**), and can be adjusted by pressing the BARO Hot Key and rotating the Right Knob.

2.3.3. Data Bar

The Data Bar visually separates the upper and lower halves of the display. GPS Ground Speed (GS) and Barometric Pressure Setting are presented in the Data Bar (**Table 2-7** and **Figure 2-24**).

When any of these values are not available or invalid, the corresponding data field is dashed. When ground speed is not displayed, the “Degraded Mode” function is not available. A GPS navigator must be connected and providing valid ground speed and ground track to display GS.

The Data Bar is discussed in detail in **Section 4.3**.

DATA BAR	
28	Barometric Pressure Setting Field
29	Ground Speed (GS)

Table 2-7
Data Bar Components



Figure 2-24
Data Bar Components

2.3.4. Navigation Display

The lower half of the EFI is the Navigation Display (**Table 2-8** and **Figure 2-35**), which shows a wide range of navigation information and flight data, including:

- Course Pointer and Heading Bug.
- 360° and ARC Compass rose display modes.
- Numeric displays of current magnetic heading, selected heading (HDG), and selected course (CRS).
- Ground Track Marker.
- Vertical Speed Indicator (VSI) tape and numerical rate value.
- Rate of Turn Indicator.
- Course Deviation Indicator (CDI) , navigation source information.
- Caution annunciations for abnormal GPS status.

NAVIGATION DISPLAY			
30	Navigation Display	39	Vertical Speed Numerical Value
31	Owship Symbol	40	Vertical Speed Indicator Tape
32	Course Pointer	41	Select CDI Navigation Source
33	Rate of Turn Indicator	42	Left Knob State
34	Ground Track Marker	43	Right Knob State
35	Numerical Direction Indicator	44	Hot Ket Legend
36	Selected Course (CRS) Field	45	CDI TO/FROM/LOC Indicator
37	Selected Heading (HDG) Field	46	CDI Lateral deviation indicator
38	Heading Bug		

Table 2-8
Navigation Display Components

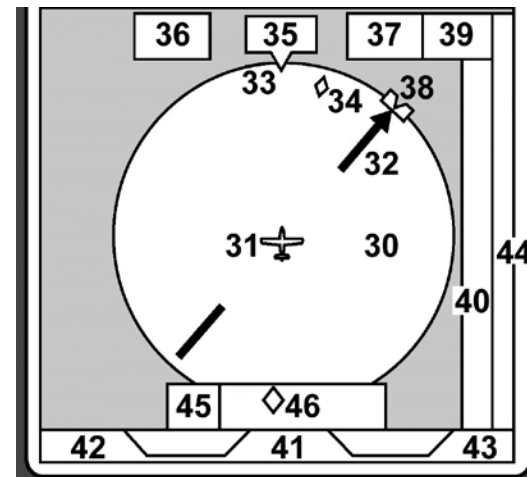

Figure 2-25
Navigation Display Components



Figure 2-26
360° Compass Mode



Figure 2-27
ARC CDI Compass
Mode

2.3.4.1. Numerical Direction Indicator

The center of the Navigation Display is the Numerical Direction Indicator. Like a magnetic compass, the NDI always shows the current magnetic heading of the aircraft. This NDI compensates both for the turning and acceleration errors exhibited by wet compasses and for precession errors found in common Directional Gyros. The pilot does not ever need to make adjustments to the NDI.

The E5 Dual EFI Direction indicator is a course pointer with CDI lateral deviation, to/from indicator and heading bug.

Compass Modes: 360° vs. ARC

The NDI on the EFI can be presented in either a full 360° Compass Mode (shown in **Figure 2-26**), or in a 100° ARC mode (**Figure 2-27**).

The 360° Compass Mode resembles the mechanical instrument, with the ownship position in the center of the display.

The ARC Compass Mode provides an extended forward view with the ownship position near the bottom of the Navigation Display.

The 360/ARC Hot Key is used to toggle the display between 360° and ARC Compass Modes, with the current mode shown in green adjacent to the Hot Key.

Navigation Information

Regardless of Compass Mode setting, the current magnetic heading is always shown at the top center of the Navigation Display (**Figure 2-2, Ref. 35** and **Figure 2-28**). The HDG Bug setting is shown in the Selected Heading Field (**Figure 2-2, Ref. 37**). This field is always visible even if the HDG Bug itself is only partially visible in ARC Compass Mode. The current Course setting (CRS) (**Figure 2-2, Ref. 36**) is always shown, whether or not the Course Pointer itself is visible in ARC Compass Mode.

Ground Track Marker

When the EFI is connected to a compatible GPS, a blue Ground Track Marker is displayed on the compass rose at the value that corresponds to the aircraft's ground track (**Figure 2-2, Ref. 34** and **Figure 2-29**).

When the Ground Track Marker is aligned with the Course Pointer, the aircraft is tracking on, or parallel to its desired track.

To align the Ground Track Marker with the Course Pointer, turn away from the direction in which the marker is offset from the Course Pointer (think of it as a turn to pull the Ground Track Marker toward the Course Pointer).

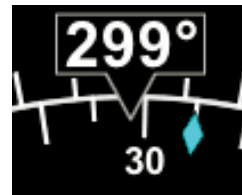

Figure 2-28
Magnetic Heading



Figure 2-29
Ground Track Marker



Figure 2-30
360 compass mode



Figure 2-31
ARC compass mode



Figure 2-32
Off Scale Deviation Diamond

2.3.4.2. Course Pointer and **Course Deviation Indicator (CDI)**

In the 360° Compass Mode, the Course Pointer and CDI displays an arrowhead pointing to the selected course, and a fixed CDI at the bottom of the display, similar to the LDI and resembling that used in contemporary GPS navigation displays. A TO/FROM/LOC indication is shown to the left of the course deviation scale. (**Figure 2-30**)

The ARC CDI Mode presents a short Course Pointer stub on the compass arc and a fixed CDI at the bottom of the display, similar to the LDI and resembling that used in contemporary GPS navigation displays. A TO/FROM/LOC indication is shown to the left of the course deviation scale. (**Figure 2-31**)

2.3.4.3. **Deviation Off-Scale Indication**

Whenever the course deviation exceeds the maximum displayable range of 2.5 dots, the CDI or deviation diamond is shown as a hollow, ghosted image pegged to the corresponding side (**Figure 2-32**). As soon as the CDI or deviation diamond comes into range, it turns solid green, making it easy to identify when the indicator is “alive”.

2.3.4.4. **Auto Course Select**

When Auto Course Select is enabled, the GPS will automatically set the Course Pointer to the current GPS course (CRS) value whenever the GPS sequences between waypoints. This capability relieves the pilot from having to manually set the course at each waypoint along a GPS route. When Auto Course Select is enabled, the pilot cannot adjust the CRS value.

Auto Course Select is indicated by an inverse A on a green background, adjacent to both the numerical CRS value and the CRS Left Knob State. (**Figure 2-33** and **Figure 2-34**).

If the GPS navigator enters the OBS or HOLD mode, Auto Course Select is automatically disabled until the GPS navigator resumes waypoint sequencing. The pilot can disable Auto Course Select from Page 1 of the Menu.

2.3.4.5. Rate of Turn Indicator

A Rate of Turn Indicator (**Figure 2-2, No. 33**) with a range of 0 to 6 degrees per second is provided for both the 360 and ARC Compass Modes. The indicator consists of a curved white tape that extends from the Numerical Heading Indicator's lubber line and in the direction of the turn, along the outer curve of the compass card.

The Rate of Turn Indicator features an outer thick white tick mark for a Standard Rate turn, and an inner thin white tick mark for Half-Standard Rate turns. A Standard Rate, two-minute turn equals 3 degrees per second. When the rate of turn exceeds 6 degrees per second, an arrowhead is added to the end of the tape to show that the rate of turn has exceeded the limits of the indicator (**Figure 2-35**).



Figure 2-33
Auto Course Indication on CRS Field



Figure 2-34
Auto Course Indication over Left Knob



Figure 2-35
Rate of Turn Indicator, Rate Shown >6°/second



NOTE

The Rate of Turn Indicator is removed while in Degraded Mode.



Figure 2-36
VSI Tape Showing 370 fpm Descent



Figure 2-37
VSI Tape Capped, Digital Value
Showing 2,100 FPM Climb

2.3.4.6. Vertical Speed Indicator (VSI)

Whenever the vertical speed exceeds +/- 100 feet per minute (fpm), the vertical speed is indicated by a rising/sinking white vertical tape and associated scale markers immediately to the right of the compass rose (**Figure 2-2, No. 40** and **Figure 2-36**).

A numerical value of the aircraft's vertical speed is shown directly above the tape, in the upper right-hand corner of the Navigation Display (**Figure 2-2, No. 39**). Rates of up to $\pm 2,000$ fpm are indicated by the tape, while the numerical value will display rates of up to $\pm 9,990$ fpm. A white triangle caps the tape whenever rates exceed $\pm 2,000$ fpm (**Figure 2-37**). The Vertical Speed Numerical Value will be dashed whenever the vertical speed exceeds +/- 10,000 fpm. In the ARC Compass Mode, only the Vertical Speed Numerical Value is presented.

Chapter 3

Flying the E5 Dual EFI

This chapter provides an overview of flying the EFI on a cross-country flight, explaining how to access and change the necessary settings of the EFI.

While you can jump right in to using the EFI with this chapter, it may be helpful to first read **Chapter 2** to become more familiar with the controls, operating logic, and display elements.

The E5 Dual EFI is a powerful Electronic Flight Instrument System (EFIS), offering the same capabilities and features found in larger glass cockpit systems in airliners, business jets, and newer general aviation aircraft. It is capable of far more than the analog instruments it typically replaces. It will take some time and experience to master all of its advanced capabilities, especially if this is your first exposure to flying an EFIS and a glass cockpit. Nonetheless, in its most basic configuration, the EFI will look immediately familiar to anyone accustomed to flying mechanical instruments, and its basic operation is very similar and intuitive.

Before flying your new display on an actual flight, first be sure to spend some time with your installer to understand exactly how your aircraft is configured. It's also recommended to get some dual instruction and practice until you are comfortable with how the display performs and integrates with the other avionics in your airplane.

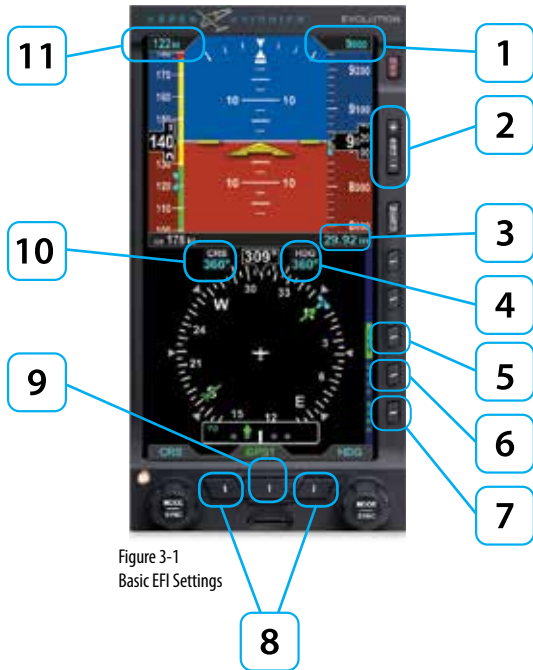

Figure 3-1
Basic EFI Settings

FEATURE		SETTING	FEATURE		SETTING
1	Selected Altitude	Set as desired	7	Barometric Pressure (BARO) Hot Key	Allows for BARO adjustment
2	Map RNG (Range) Buttons	No E5 Dual EFI Functionality	8	Left and Right Buttons	No E5 Dual EFI functionality
3	Barometric Pressure Setting Field	Adjustable	9	CDI Navigation Source Select (Middle Button)	Select as desired
4	Heading Bug Value	Set as desired	10	Selected Course (CRS) Pointer Field	Set as desired
5	Compass Mode Hot Key: 360 or ARC	Set as desired	11	Selected Airspeed	Set as desired
6	GPS Steering (GPSS) Hot Key ¹	on/off			

Table 3-1 Basic EFI Settings

1. ACU may be required

3.1. Quick Controls Overview

Chapter 2 explains the EFI controls in detail. The following is a quick summary:

Knobs

*(See **Chapter 2, Section 2.2.1.** for details)*

The Left or Right Knob each has a Home State, to which it returns after 10 seconds of inactivity. The Left Knob is the CRS Knob, and the Right Knob is the HDG Knob.

- The current function of each knob is shown by its State, displayed immediately above the knob. If the knob state is shown in magenta, turning the knob will change the value of the function shown. If the legend is shown in cyan or green, turning the knob will have no effect.
- From the Home State, pressing the knob once will enable the current function to be set (Knob State color changes from cyan to magenta). Successive presses of the knob will cycle through the functions that knob can control. When the function you want to change is shown in magenta, turning the knob will change its value.
- The Left Knob sets the Course Pointer (CRS, except when Auto Course Select is enabled) and Indicated Airspeed Bug (IAS).
- The Right Knob sets Heading (HDG), Selected Altitude (ALT), and Barometric Pressure Setting (BARO).
- Pressing and holding a knob syncs the selected function.

Navigation Source Buttons

- Buttons at the bottom of the display couple the available navigation sources to the CDI.
- The Center Button - CDI Navigation Source Select Button (**Figure 3-1, Ref. 9**) selects the nav source to couple to the CDI and to drive the autopilot (if installed).

Hot Keys

- The three lower keys on the lower right-hand side of the display are Hot Keys, (**Figure 3-1, Ref. 5, 6 & 7**) the function of which is shown by the legend on the screen immediately adjacent to each key.
- The current status of each Hot Key is shown by the legend in a green label and dark blue letters if active or, in a blue label and green letters if inactive or, in an amber label and dark blue letters if in a coast state.
- Each press of a Hot Key will either toggle its function on or off, or will cycle among available settings (see **Chapter 2, Section 2.2.3** for details).

3.2. Example Flight Scenario

This section will walk you through using the EFI on a flight from Albuquerque International Sunport (KABQ) to Reno/Tahoe International Airport (KRNO), flying Victor airways. This scenario uses one pilot's technique for setting up the navigation instruments, but there are many other valid possibilities. Use whatever techniques work best for you.

Our aircraft for this example flight scenario is a typical single engine aircraft equipped with a single Garmin GNS-430W WAAS GPS/Nav/Comm and the Bendix/King KFC-150 Autopilot. The E5 Dual EFI is configured with Auto Course Select enabled (in the main menu), BARO setting in inches Hg, Vspeed text markers displayed, and ARC compass mode.



NOTE

The tasks and procedures you will use in your airplane will vary depending on your aircraft and equipment, and on how they are configured and integrated with the display in your specific installation



Figure 3-2
E5 Dual EFI Initializing



Figure 3-3
CDI Navigation Source Slashed Invalid

3.2.1. Pre-Departure (Startup)

Once the pre-flight inspections and checklists are complete, start the engines and turn on the EFI Master switch.

When power is applied the bezel backlighting illuminates and within a few seconds the splash screen displays while it initializes and the AHRS data is validated (**Figure 3-2**).

As the software initializes and the EFI warms up, the Attitude and Navigation Displays will appear first (typically around 30 seconds), with red X's showing for the airspeed and altitude tapes and the CDI Navigation Source is slashed as invalid (**Figure 3-3**). Depending on how cold the aircraft is, the air data sensors will quickly warm to operating temperature, and the airspeed and altitude tapes will appear. At this point, the red X's will disappear and, the EFI is ready.

NOTE

Start-up times are highly dependent on aircraft temperature. In extremely cold weather, when the aircraft has been cold soaked, it may take several minutes (usually no more than five) for the EFI to be fully operational. On the second or third flight of the day, and/or on very hot days, it may initialize within 30 seconds or less.

Turn the Avionics Master ON. Until the navigation radios are operational, the CDI Navigation Source annunciations on the EFI is slashed as invalid (**Figure 3-4**), and the GPS1 caution annunciation on the left (**Figure 3-5**), display. The CDI Navigation Source Select will default to VLOC1 the first time the EFI is turned on. Once the nav radio has warmed up, the red line will be removed from the CDI Navigation Source annunciation.



Figure 3-4
CDI Source Slashed Invalid



Figure 3-5
GPS Caution Annunciations

NOTE

GPS navigators will not output valid navigation information until programmed with an active flight plan or direct-to waypoint, and thus will be treated as invalid by the EFI and cannot be selected as a CDI navigation source until they are programmed with an active waypoint.

When the EFI is interfaced to a compatible GPS navigator, and the navigator's Instrument Panel Self-Test page is displayed, the indicated lateral deviation can be verified on the display. This confirms that a valid digital signal has been received from the Garmin system.

The interface between the GPS NavCom and the EFI system should be considered fully operational once the presence of the digital signal is confirmed. If there is no GPS failure annunciation on the EFI the lateral deviation indication correlates to the indication on the compatible GPS Navigator's and Self-Test Page, and then the digital signal is confirmed, and the interface is operational.

NOTE

The graphics used in this chapter illustrate the descriptions of the features and tasks, but do not necessarily correspond to the values associated with this example flight scenario.

WARNING

Whenever there is a new altimeter setting, set both the E5 Dual EFI and the standby altimeter.



Figure 3-6
BARO Setting Field Enabled



Figure 3-7
BARO Setting Field Disabled

Once the radios are available, we listen to the ATIS and learn that the local altimeter setting is 30.15 and that Runway 8 is in use for departures.

First set the standby altimeter to 30.15, and then set the EFI barometric pressure setting.

Set the Barometric Pressure

1. Press the BARO Hot Key. The BARO label above the Right Knob and Barometric Pressure Setting Field appear in magenta - enabled for editing (**Figure 3-6**).
2. Rotate the Right Knob clockwise to increase or counterclockwise to decrease the value of the Barometric Pressure Setting Field.
3. Once the correct value is selected, press the BARO Hot Key or any knob, button/key to exit the BARO function. After 10 seconds of inaction or if any other button/key is pressed, the BARO function is disabled and the Right Knob returns to normal operation (**Figure 3-7**).

Next, since we'll be departing from Runway 8, we set our Heading Bug to runway heading, 080°.

Set the Heading Bug

1. Press the Right Knob until HDG displays above the knob and the HDG field is enabled for editing, both rendered in magenta (**Figure 3-8**). The Heading Bug will also be rendered in magenta, and a dashed magenta line will extend from the ownship symbol to the Heading Bug to make it easier to see the bug position.
2. Rotate the Right Knob to change the value of the Selected Heading field. Rotate clockwise to increase, or counterclockwise to decrease, the value. Once the correct heading is selected and after 10 seconds of inaction, the field is disabled, and the label and field are rendered in cyan (**Figure 3-9**).

We call Clearance Delivery to pick up our clearance. It is:

Cessna N1234 is cleared to the Reno/Tahoe Airport as filed; Maintain 7,000; Expect 10,000 in five minutes; Departure frequency is 127.4; Squawk 0123.

We copy and read back our clearance, and then set up our avionics for departure. We set our transponder code and comm radio frequencies. Then we enter our flight plan into GPS1, and activate the flight plan. We make sure the CDI button on the GPS Nav/Com is set to GPS.

From past experience, we expect to be vectored past ABQ VOR, and then given a vector to join the departure on the ABQ-to-ZUN leg (a 255° course). While we navigate with GPS, we tune the ABQ VOR into our nav radio.



Figure 3-8
Selected Heading Field Enabled



Figure 3-9
Selected Heading Field Disabled



Figure 3-10
CDI Navigation Source Selection Button

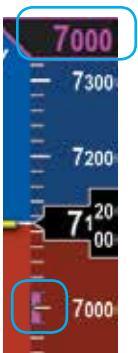

Figure 3-11
Altitude Bug Enabled

Select GPS1 as the CDI Navigation Source. Because we have enabled Auto Course Select, the Course Pointer automatically slews to 261° (the initial course from the airport to the first fix on the LARGO2 departure, ABQ VOR).

Select the CDI Navigation Source

- Press the CDI Navigation Source Select Button (**Figure 3-10**) until the desired navigation source is shown above the Button (in this case, GPS1).

Altitude

Next, we set our assigned initial altitude of 7,000 feet in the Selected Altitude Field. We press the Right Knob twice, changing the legend above the knob to ALT in magenta. Then we turn the Right Knob to set 7,000. This will help us capture and maintain our assigned altitude.

Set the Altitude

1. Press the Right Knob until ALT displays above the Right Knob and the Selected Altitude numerical field and Bug are enabled for editing, all three rendered in magenta (**Figures 3-11 and 3-12**).
2. Rotate the Right Knob to change the value of the Selected Altitude field. Rotate clockwise to increase, or counterclockwise to decrease, the value.
3. Once the correct value is selected, and after 10 seconds of inaction, the field is disabled and the label, Selected Altitude field, and Bug are rendered in cyan (**Figure 3-13**).



Figure 3-12
Altitude Field Enabled



Figure 3-13
Altitude Disabled

NOTE

*Synchronizing the altitude sets the selected altitude to the current altitude (see **Chapter 2, Section 2.2.1.3.**)*



Figure 3-14
Selected Airspeed Field Enabled



Figure 3-15
Selected Airspeed Field Enabled



Figure 3-16
Selected Airspeed Field Disabled

Our normal climb speed is 120 KIAS, so we set the Airspeed Bug as a reminder. To do so, we press the Left Knob twice, until it shows IAS in magenta above the knob. Then turn the knob until 120 shows in the Selected Airspeed Field.

Set the Airspeed Bug

1. Press the Left Knob until IAS displays above the Left Knob and the Selected Airspeed field and bug are enabled for editing, all three rendered in magenta (**Figures 3-14 and 3-15**).
2. Rotate the Left Knob to change the value of the Selected Airspeed field. Rotate clockwise to increase, or counterclockwise to decrease, the value.
3. Once the correct value is selected, and after 10 seconds of inaction, the field is disabled, and the label and field are rendered in cyan (**Figure 3-16**).

Now our avionics are all set, so we taxi out to the runway, do our run-up, and call tower, ready for departure. As we taxi into position and hold on Runway 8, we verify that our E5 Dual EFI compass shows 080°, lined-up with our pre-set Heading Bug. As tower clears us for takeoff, it tells us to wait until reaching the end of the runway, and then to turn left to heading 250°. Rotate the Right Knob to set the Heading Bug to 250°.

NOTE

*Synchronizing the airspeed sets the selected airspeed to the current airspeed (see **Chapter 2, Section 2.2.1.3.**)*

3.2.2. Departure

As we start the takeoff roll, we note the airspeed on the airspeed comes “alive” at 20 KIAS. All indications are normal, so we continue the takeoff, rotate at 80 KIAS. As we run out of usable runway to land, we bring the gear up, and soon we’re over the end of the 13,800 ft. runway.

We engage HDG mode on the autopilot mode selector, and turn to our assigned 250° heading, which we have already set with the Heading Bug. Through 1,000 feet AGL, we power back and adjust the pitch attitude to maintain our target 120 KIAS climb speed, as shown by the Airspeed Bug on the airspeed tape.

We begin to shallow our climb, and level off at 7,000 feet, engaging ALT hold on the AP mode selector (**Figure 3-17**).

While on the 250° vector, we pass abeam the ABQ VOR. We also notice that the GPS then sequences to the next flight plan waypoint, the ZUN VOR.. The Course Pointer automatically swings left to the new course, 255°.

Albuquerque Departure now tells us to fly heading 220°, and climb and maintain 10,000. Departure also calls out slower traffic at our 10 o’clock, seven miles, west-bound at 8,000, and asks us to expedite our climb through 8,000.

1. Rotate the Right Knob and turn it left to set the Heading Bug to 220°.
2. Press the Right Knob twice to activate ALT, and turn it right to set 10,000 in the Selected Altitude field at the top of the Altitude Tape.



Figure 3-17
Selected Altitude Field



Figure 3-18
CDI Shown Hollow at Full-Scale Deflection



Figure 3-19
CDI "Alive" and Shown Solid

Auto Course Select has already set our Course Pointer to the 255° course from ABQ to ZUN and a 220° heading sets us up for a nice intercept. We pitch a little higher to climb at 115 KIAS through 8,000 for traffic, then lower the nose to maintain our target airspeed of 120 KIAS by reference to the Airspeed Bug.

At about 9,700 feet, we begin our level-off, and upon reaching 10,000 feet, engage ALT hold on the autopilot's mode selector.

Departure calls again to hand us off to Albuquerque Center on 133.0. As we're tuning the radio, we glance at the selected altitude field, our altitude indicates 10,200 and climbing. We quickly stop the climb, correct back down to our assigned altitude of 10,000, and engage the autopilot before calling to check in with Center.

3.2.3. Enroute

Albuquerque Center gives us a new altimeter setting of 30.11. We set 30.11 on the standby altimeter and then on the EFI.

- Press the BARO Hot Key and rotate the Right Knob to set 30.11.
- Press the BARO Hot Key, or any knob, button/key to exit.

Soon, the CDI comes “alive” and attracts our attention as it changes from hollow (**Figure 3-18**) to solid green (**Figure 3-19**) and begins to move in towards the Course Pointer as we intercept our course. We enable GPSS to complete the intercept and steer us along the airways all the way to Reno, and engage the autopilot.

Engage GPSS¹

1. Press the GPSS Hot Key to Enable GPS Steering (**Figure 3-20**).
2. Verify indications that GPSS is now enabled.
 - The GPSS legend adjacent to the GPSS Hot Key should be shown in inverse green.
 - The annunciation GPSS1 along with an inverse A, should be shown next to the HDG reference at the top of the navigation display (**Figure 3-21**).
3. Select HDG mode on the autopilot’s mode selector.
4. Engage the autopilot (if desired).



Figure 3-20
GPSS Enabled legend in Green



Figure 3-21
GPSS Enabled

1. Requires ACU option to enable autopilot / GPS Steering



Figure 3-22
360° Compass Mode



Figure 3-23
ARC CDI Compass Mode

GS 178 kt 29.92 in

Figure 3-24
Data Bar

With GPS Steering (GPSS), a compatible GPS navigator (in this case, a Garmin 430W) drives the autopilot directly via the autopilot's HDG mode, telling it how to bank to stay centered on course. GPSS can drive the autopilot far more accurately than the NAV mode (which is based on course deviation indications) because the GPS always knows the ground track and how to adjust to maintain that track, implicitly accounting for changing wind conditions. The GPS also includes turn anticipation based on current ground speed and track, enabling it to turn early and roll out centered on the new course without overshooting.

Select a Compass Mode

- Press the 360/ARC Hot Key to alternately select either the 360° (**Figure 3-22**) or the ARC (**Figure 3-23**) Compass Mode.

We set cruise power and lean the mixture. As the airplane stabilizes in cruise, we check the Data Bar to monitor ground speed (**Figure 3-24**)

Once the airport is in sight we disconnect the autopilot and hand fly the plane down to a smooth landing.

3.3 Conclusion

The E5 Dual EFI is a powerful addition to any cockpit, providing far more capability, information and automation than the mechanical instruments it typically replaces. While it is simple and intuitive enough to start using with only a short orientation, fully understanding and exploiting all of its features require some study and experience.



CAUTION

The Garmin 400/500 series navigators continue to output GPS Steering commands to follow the GPS flight plan even when the CDI source is set to VLOC.

The EFI permits GPSS to be enabled even when VLOC is selected as the CDI navigation source.

Whenever the GPSS is on and the autopilot is in the HDG mode, the autopilot will fly the GPS flight plan.

Chapter 4

Reference Guide

The E5 Dual EFI is a panel-mounted Electronic Flight Instrument System (EFIS) that presents the pilot with displays of attitude, altitude, indicated airspeed, heading, rate of turn, slip/skid, and navigation course deviation information. The system also displays supplemental flight data, such as groundspeed and pilot-selectable indices (bugs), to increase situational awareness and enhance flight safety.

The system components include the EFI display head, a Remote Sensor Module (RSM), a Configuration Module (CM), and the optional Analog Converter Unit (ACU). **Chapter 1, Welcome and Introduction**, provides a detailed discussion on the system components.

When interfaced with a compatible autopilot, the EFI system provides heading and course information to the autopilot, which enables the autopilot to follow the Course and Heading values set by the pilot on the display. When interfaced with a compatible GPS, the EFI can provide GPS Steering (GPSS) to an autopilot.

NOTE

The optional ACU enables the interface of the E5 Dual EFI system with legacy panel-mounted GPS navigators, VOR radios, and autopilots.

4.1. Air Data, Attitude and Heading Reference System (ADAHRS)

One of the many benefits of glass cockpit systems like the Aspen Evolution system is that they replace old, less-reliable mechanical instruments and sensors with electronic equivalents. For aircraft primary flight instruments, spinning metal gyros are replaced with electronic gyros and accelerometers, and mechanical air data instruments (airspeed indicator, altimeter, and VSI) are replaced by electronic sensors to measure static and ram air pressures. As we've all seen with computers and consumer goods, these modern electronic systems tend to be smaller, faster, cheaper, and more reliable than the older technologies they replace, while also enabling many new, advanced features and capabilities.

An electronic system that replaces the functions of the six primary flight instruments is often called an ADAHRS (Air Data, Attitude, and Heading Reference System). Sometimes, two separate systems work together to deliver those functions: an AHRS for attitude and heading, and an ADC (Air Data Computer) for airspeed, altitude, and vertical speed. Aspen uses an integrated ADAHRS mounted to the back of the display. While such systems deliver the same basic information to the pilot as the old mechanical instruments, they work in very different ways. It is important that the pilot have at least a basic understanding of how an ADAHRS works to better understand the sorts of failure modes or degraded performance that can occur, how to recognize the symptoms, and what corrective actions the pilot can take.

The EFI uses Micro Electro-Mechanical Systems (MEMS) technology and solid-state accelerometers and magnetometers on all three axes to provide the attitude reference. Generally, MEMS attitude solutions use multiple sensors and inputs, processed through Kalman filter software, to derive and validate the attitude solution.

The Aspen system uses many different inputs to determine and monitor the aircraft attitude. In this way, the system can validate the derived attitude indication by cross-checking the various inputs to the solution for consistency.



Figure 4-1
Cross Check Attitude
Annunciation

4.1.1. Attitude

The Aspen ADAHRS attitude solution uses inputs from its internal three-axis accelerometers, rate gyros, and magnetometers, supplemented by ram and static air pressure inputs from the aircraft pitot-static system. Failures or incorrect input from any of these sensors (such as might occur if the pitot tube or static system become blocked) will affect the attitude solution. The EFI is designed to be robust to such failures, either by being tolerant to incorrect inputs, or by detecting and annunciating a degraded attitude solution.

The Aspen ADAHRS includes a Cross-Check Monitor, which predicts the quality of the attitude solution by performing a continuous, real-time statistical analysis of the various parameters computed within the AHRS Kalman filter. When the predicted quality of the attitude calculation drops below a certain threshold, CROSS CHECK ATTITUDE is annunciated on the attitude indicator (**Figure 4-1**). The annunciation thresholds for the CROSS CHECK ATTITUDE message were determined during company flight tests, and strike a balance between minimizing nuisance annunciations (when the attitude solution is fine) and failing to annunciate (when the attitude solution is significantly reduced). This balance can occasionally result in momentary CROSS CHECK ATTITUDE annunciations, especially during aggressive maneuvering, steep or high-G turns, abrupt pitch changes, etc.

In such situations, these annunciations indicate that the statistical quality of the attitude solution is less than nominal, and that the pilot should cross-check the AHRS against alternate attitude indications. Should the annunciation persist, then degraded AHRS performance is statistically more likely to be experienced. In other words, momentary CROSS CHECK ATTITUDE annunciations indicate that the AHRS solution is working hard enough that the AHRS quality measure has been reduced to something less than that associated with normal, unaccelerated flight. This situation demands increased pilot vigilance and cross-monitoring of other cockpit instrumentation.

4.1.2. Pitot Obstruction Monitor

Most light aircraft have only a single pitot and static system available for flight instrument use. As such, a common pitot and static input is shared between the EFI and analog standby instruments. Should one or both of these pitot and static lines become blocked, both the EFI and any standby airspeed and altitude indicators could display erroneous airspeed and altitude information. Furthermore, because the EFI uses pitot and static pressures as part of the AHRS attitude calculations, loss or corruption of the pitot or static pressures can also influence the accuracy of the displayed attitude information.

The EFI has been tested to be robust to these failures, either by being tolerant to incorrect pitot or static inputs, or by detecting and annunciating a degraded attitude solution. When connected to an IFR-certified GPS, the system is further able to detect and annunciate blockages in the pitot system and will use GPS ground speed instead of IAS as part of the AHRS solution. In that case, the system will continue to provide attitude and heading information, and display a ATTITUDE DEGRADED message as a reminder to the pilot to check for ice accumulating on the pitot probe (**Figure 4-2**).

Once the system detects that the pitot obstruction has been cleared, the ATTITUDE DEGRADED annunciation is removed and the system automatically performs an AHRS in-flight reset.

Should a GPS failure be experienced in flight, the Pitot Obstruction Monitor continues to operate in a fail-safe mode and will continue to detect obstructions in the pitot system that may occur while airborne. However, after landing, the monitor remains active, and, as the airplane slows to taxi speeds, the system will indicate a failure of the AHRS and annunciate CHECK PITOT HEAT. In this circumstance, restoring the GPS will restore normal monitor operation.



Figure 4-2
Attitude Degraded

NOTE

Should a loss of GPS occur at the same time the EFI is in Attitude Degraded mode, the system will red X the attitude and heading information and display a CHECK PITOT HEAT message as a reminder to the pilot to check for ice accumulating on the pitot tube.

In summary, loss or degradation of the EFI attitude solution is unlikely if the pilot assures the proper operation of the pitot-static system. If the pitot or static system becomes blocked, an ADAHRS internal sensor fails, or a CROSS CHECK ATTITUDE followed by an ATTITUDE DEGRADED indication is frequent or persists, the attitude indication on the EFI should be considered to be compromised. In this case, the pilot must crosscheck other instruments for attitude reference until the cause of the problem has been identified and resolved and normal system operation has been restored.

4.1.3. Heading

The ADAHRS also includes a slaved compass system that provides accurate magnetic heading indications throughout most operating conditions and phases of flight. Its electronic gyros compensate for turning and acceleration errors, and its remote fluxgate compensates for gyroscopic precession errors, so there is no need for the pilot to adjust heading throughout the flight. Nonetheless, all compass systems are subject to some error, and the pilot should be aware of when and how the heading indication can be affected.

The earth's magnetic field is measured directly by a 3-axis fluxgate magnetometer built into the Remote Sensor Module (RSM), and magnetic heading is derived from the flux on a plane perpendicular to gravity, providing immunity from pitching and rolling effects. Electronic gyros and accelerometers in the system are then used to stabilize that raw heading data to eliminate the short-term turning and acceleration errors seen in traditional magnetic compasses.

Together, these systems provide accurate heading indications even during aggressive maneuvering. The gyros stabilize magnetic errors while maneuvering and are slaved to the fluxgate, which continuously updates heading to compensate for gyroscopic precession. The end result is a compass system that requires no pilot action to show accurate magnetic heading throughout the flight.

Just like other compass systems, the accuracy of the fluxgate is affected by its location on the airframe. Ferrous metal structures, electrical fields produced by motors, pumps, wiring, magnets in cabin speakers and other airframe-related sources of interference either constant or momentary (i.e. operating an electric trim motor, windshield heat, pumps, etc) can all affect the accuracy of the compass. The installer can compensate for much of this interference when calibrating the RSM, but some effects cannot be eliminated. Proper location of the RSM during installation is critical to the AHRS performance and accuracy.

Furthermore, all magnetic compass systems are susceptible to local disturbances in the earth's magnetic field (some of which are shown on aviation charts or by NOTAM) and will exhibit degraded performance when operating in extreme northern and southern latitudes close to the earth's magnetic poles.

4.1.4. Free Gyro Mode

When the E5 Dual EFI system detects that the horizontal component of the earth's magnetic field is no longer strong enough to provide reliable heading data, it will detect the condition and annunciate that the heading system is no longer slaved to magnetic north. If the condition persists, attitude and heading indications are removed.

While the condition can occur at greater distances, it is most likely to be observed within 750 nautical miles from the magnetic poles. In the Northern Hemisphere, this equates to operations in the Arctic Islands found north of continental North America.

Two minutes after detection, a FREE GYRO MODE annunciation will be presented across the Navigation display, indicating the heading system no longer can be aligned with magnetic north. Some precession of the heading is possible, especially during abrupt maneuvers. If the condition persists for four more minutes (six minutes total) the attitude and heading indicators will be removed and replaced with red X indications. When the conditions causing Free Gyro Mode are no longer present, attitude and heading indications will be restored after an automatic AHRS reset.

4.1.5. Degraded Mode

For Degraded ADAHRS Performance, reference the following:

- **Sections 6.1. Pitot/Static System Blockage**
- **Sections 6.8. In-Flight AHRS Reset**
- **Geographic Limitations** in the **Aircraft Flight Manual Supplement** that was installed in the aircraft with your EFI.

4.2. Attitude Display

4.2.1. Attitude Indicator

The Attitude Indicator consists of an aircraft reference symbol on a blue (sky) and brown (ground) background. The white horizon line separates the sky from the ground and extends to the edge of the display. The Roll Scale curves over the top of the Attitude Indicator while the Pitch Scale extends vertically in the middle. The slip/skid rectangle is directly underneath the roll pointer (**Figure 4-3**).

1	Sky	5	Pitch Scale
2	Aircraft Reference Symbol	6	Roll Scale
3	Horizon Line	7	Roll Pointer
4	Ground	8	Slip/Skid Indicator

The Attitude Indicator cannot be disabled by the pilot. The Aircraft Reference Symbol is fixed relative to the Attitude Indicator and overlays all other Attitude Indicator symbols. Pitch and roll panel tilt adjustments are provided to installers to compensate for variations in installations and tilted panels.

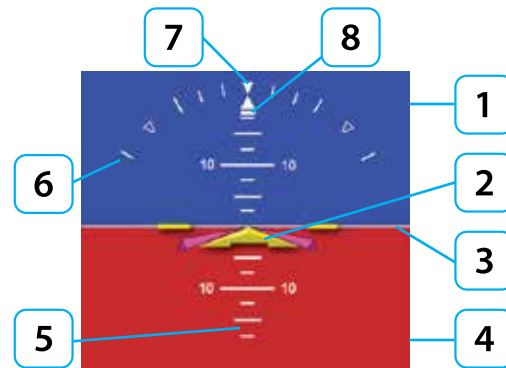

Figure 4-3
Attitude Indicator



Figure 4-4
Pitch and/or Roll Data Invalid

Figure 4-4
Pitch and/or Roll Data Invalid

NOTE

A red X and the annunciation ATTITUDE FAIL displays on the Attitude Indicator as long as pitch or roll attitude data is invalid (**Figure 4-4**).

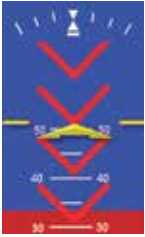

Figure 4-5
Pitch Markings
Large Pitch Down



Figure 4-6
Pitch Markings
Large Pitch Up

4.2.1.1. Roll Scale

The Roll Scale is displayed at the top of the Attitude Indicator and comprises a moving scale set against a fixed, white, triangle roll pointer (**Figure 4-3, Ref 6 & 7**). Tick marks are displayed at 0°, 10°, 20°, 30°, 45°, and 60° of roll. The 45° marks are triangles.

4.2.1.2. Pitch Scale

The pitch scale consists of minor pitch marks in 2.5° increments up to $\pm 20^\circ$ and major pitch marks in 10° increments up to $\pm 90^\circ$ (**Figure 4-3, Ref 5**). Red chevrons come into view for nose-up pitch angles of 15° or more (**Figure 4-5**), and nose-down pitch angles of 10° or less (**Figure 4-6**). The pitch chevrons aid the pilot in unusual attitude recovery.

The range of movement of the background sky and ground boundaries are limited so that some sky or ground is always visible.

4.2.1.3. Slip/Skid Indicator

The Slip/Skid Indicator is the small white rectangle under the roll pointer (**Figure 4-3, Ref 8**). The Slip/Skid Indicator moves left and right relative to the roll pointer in proportion to lateral acceleration. The width of the rectangle is equivalent to the width of the ball in a mechanical inclinometer.

NOTE

While operating in Degraded Mode both the Slip/Skid indicator and Turn Rate indicator on the EFI will be removed. Refer to your legacy instruments for these indications..

4.2.2. Airspeed Indicator

The Airspeed Indicator comprises a moving tape, airspeed bug, and numerical airspeed value (drum). Textual Vspeeds, color Speed Bands, and Speed Markers are also rendered on the moving tape (Figure 4-7).

- 1 Selected Airspeed Field
- 2 Color Speed Bands
- 3 Textual Vspeeds
- 4 Initial Flap Extension Speed Marker
- 5 Airspeed Tape
- 6 Speed Marker
- 7 Numerical Airspeed Value (drum)
- 8 Selected Airspeed Bug

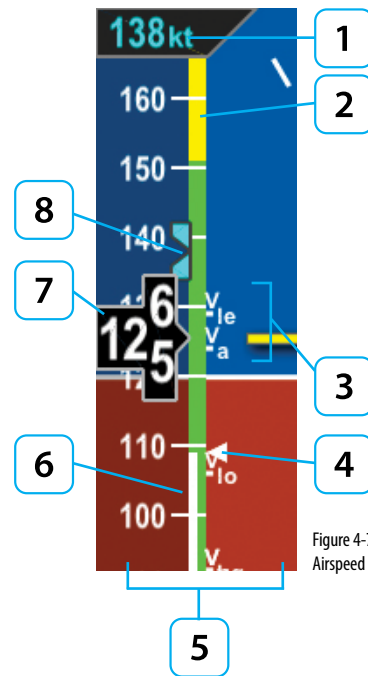

Figure 4-7
Airspeed Indicator

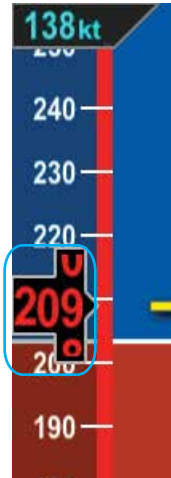

Figure 4-8
Actual Airspeed Greater Than the Vne

Indicated airspeed is displayed in knots, miles per hour or Mach number, set at installation, with tick marks rendered on the Airspeed tape every ten (10) units. Speed Bands and Speed Markers are configured during installation and cannot be changed or removed by the pilot. The textual Vspeeds are pilot-configurable and are discussed in **Chapter 5, Customizing the E5 Dual EFI**. Although the pilot can set the selected airspeed (bug), there is no visual or aural annunciation provided when the actual airspeed deviates from the selected airspeed value.

The numerical airspeed value is displayed in a rolling drum format in the center of the airspeed tape with numbers moving downward as speed increases, and upward as speed decreases. The display range of the indicated airspeed is 20–450 (knots or miles per hour). The numerical airspeed value is displayed in red when Vne is exceeded or when the airspeed drops below Vs0 during stalls or landing roll-outs (**Figure 4-8**).



Figure 4-9
Pitot Obstruction with Failed GPS

NOTE

*When airspeed is less than 30 knots and GPS has failed, a red X and annunciation of CHECK PITOT HEAT is displayed on the Attitude Indicator (**Figure 4-9**).*

4.2.2.1. Selected Airspeed

The Selected Airspeed Field value and associated Airspeed Bug are shown on the Airspeed Tape. The Selected Airspeed Field value is shown at the top of the Airspeed Tape. The Airspeed Bug is displayed next to the Airspeed Tape when the Selected Airspeed value is within the visible range of the tape. The Selected Airspeed Field's default value is 20 knots Indicated Airspeed (IAS), or the value previously set. SYNCing the IAS field sets the Selected Airspeed Field value to the current indicated airspeed (**Section 2.2.1.3**). Setting the Selected Airspeed Field to a value less than 20 disables the Airspeed Bug and dashes the Selected Airspeed Field value.

Set Airspeed Bug

1. Press the Left Knob until IAS is shown above the Left Knob.

The Airspeed Field and Airspeed Bug appear in magenta - enabled for editing (**Figure 4-10**).

2. Rotate the Left Knob clockwise to increase, or counterclockwise to decrease the airspeed value in the Selected Airspeed Field.

After 10 seconds of inactivity, label, field and bug appear in cyan (**Figure 4-11**).



Figure 4-10
Airspeed Bug Selected to Edit

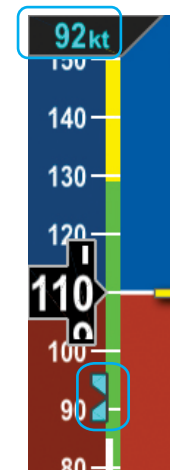

Figure 4-11
New Airspeed Selected



NOTE

A typical installation sets the Tapes (TPS) display to UNLOCKED, allowing the pilot to display or hide the Airspeed and Altitude Tapes as desired.



Figure 4-12
Editing Airspeed Tape Display



Figure 4-13
Tapes (TPS) Disabled

4.2.2.2. Airspeed Display

The airspeed tape can be turned off at the pilot's discretion to facilitate screen declutter. This setting will be retained when the system is turned off then powered on again.

Hide/Display Airspeed Tape

1. Press MENU Button.
2. Rotate Right Knob until first Menu Key displays TPS (**Figure 4-12**).
3. Press TPS Menu Key.

TPS label and EDIT VALUE label (above Right Knob) appear in magenta.

4. Rotate Right Knob to the desired value: ENABLE or DISABLE (**Figure 4-13**).
5. Press MENU Button to exit.

NOTE

The tapes can also be turned off for screen declutter. Setting will be retained when EFI is turned off.

NOTE

When the Airspeed Tape is disabled, the numerical display of the selected airspeed remains. An installer can disable and remove the Selected Airspeed Field from the display.

4.2.3. Altimeter

The altimeter comprises an Altitude Bug, Numerical Altitude Value (drum), Altitude Tape, and Selected Altitude Field value. (Figure 4-14).

- 1 Selected Altitude Field
- 2 Numerical Altitude Value
- 3 Altitude Tape

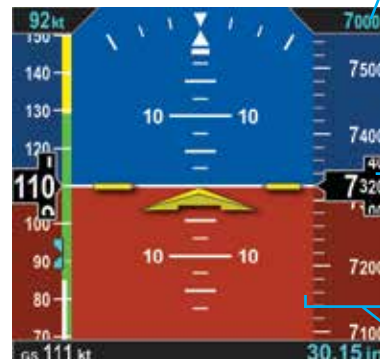

Figure 4-14
Altimeter

The Altitude Tape range is from -1,600 to 51,000 feet. Major tick marks are provided every 100 feet and minor tick marks every 20 feet. A barometric pressure adjustment (BARO) is provided to the pilot to accurately display the aircraft's altitude above mean sea level.

The Numerical Altitude Value is shown in a rolling drum format in the center of the Altimeter Tape, with numbers moving downward as the altitude increases and upward as altitude decreases. The Numerical Altitude Value shows the altitude to the nearest 20 feet.



Figure 4-15
Altitude Failure



Figure 4-16
Baro Shown in Inches of Mercury



Figure 4-17
Baro Shown in Millibars



Figure 4-18
Editing BARO
Units of Measure
GENERAL SETTINGS B



Figure 4-19
Editing BARO
from in to mB

If the altitude exceeds 51,000 feet, the Numerical Altitude Value is dashed, and the tape is frozen at this limit. All altitude information is removed and replaced with a red X with the textual annunciation of ALT FAIL when altitude data is invalid (**Figure 4-15**).

4.2.3.1. Barometric Units of Measure

Barometric units of measure adjustment may be made in either inches of mercury (in) (**Figure 4-16**) or millibars (mB) (**Figure 4-17**), as configured by the pilot in the Menu. The adjustment range is 28.10 – 30.99 inches Hg or 946 – 1049 mB. The barometric pressure default value is 29.92 inches, or as previously set.

Set Barometric Units of Measure

1. Press the MENU Button.
2. Rotate the Right Knob to select the GENERAL SETTINGS B page (**Figure 4-18**).
3. Press the BARO Menu Key.

The Menu label turns magenta, and the EDIT VALUE label displays above the Right Knob (**Figure 4-19**).

4. Rotate the Right Knob to select either in or mB (**Figure 4-20**).
5. Press the MENU Button to exit.

Set the Barometric Pressure

1. Press the BARO Hot Key.

The BARO label above the Right Knob and Barometric Pressure Setting Field appear in magenta (**Figure 4-21**).

2. Rotate the Right Knob to change the value of the Barometric Pressure Setting Field.
3. Press the BARO Hot Key or any knob, button/key to exit.

If no action is taken, after 10 seconds of inactivity, the label, and field are rendered in cyan.



Figure 4-20
BARO Set to mB (millibars)



Figure 4-21
BARO Field Enabled



WARNING

Always check and set the EFI BARO whenever the mechanical altimeter is adjusted

NOTE

Rotating the knob quickly will change the altitude value in larger increments.

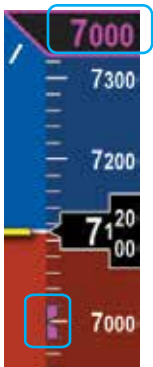

Figure 4-22
Altitude Bug

NOTE

Since the altitude tape display is limited to approximately 400 feet, the altitude bug symbol is shown on the altitude tape when the Selected Altitude Field value is within the visible range of the current altitude.

4.2.3.2. Selected Altitude Field

The Selected Altitude Field value is displayed at the top of the Altitude Tape. The Selected Altitude Field range is 100 to 51,000 feet, in 100 foot increments. The default value for the Selected Altitude value is 100 feet, or the previously set value. Additionally, the Altitude Bug is displayed adjacent to the Altitude Tape and at the Selected Altitude Field value when within the visible range of the current altitude.

Set Altitude Bug

1. Press the Right Knob until ALT displays above the Right Knob.

The Selected Altitude Field and bug are enabled for editing, all rendered in magenta (Figure 4-22).

2. Rotate the Right Knob (clockwise to increase, or counterclockwise to decrease) to change the value of the Selected Altitude Field.

Once the correct value is selected, and after 10 seconds of inaction, the field is disabled, and the label, field, and bug are rendered in cyan.

4.2.3.3. Altitude Display

The altitude tape can be turned off, at the pilot's discretion, to facilitate screen declutter. Both Airspeed and Altitude tapes are affected by this action.

Hide/Display Airspeed and Altitude Tape

1. Press the MENU Button.
2. Rotate the Right Knob counterclockwise until GENERAL SETTINGS page displays (**Figure 4-23**).
3. Press the TPS Menu Key.

The Menu label turns magenta, and the EDIT VALUE label displays above the Right Knob.

4. Rotate the Right Knob to the desired value, ENABLE (On) or DISABLE (Off) (**Figure 4-24**).
5. Press the MENU Button to exit.



Figure 4-23
Editing Airspeed and Altitude Tape Display



Figure 4-24
Airspeed and Altitude Tape Disabled

NOTE

A E5 Dual EFI installation sets the tapes display to UNLOCKED, allowing the pilot to display or hide the Airspeed and Altitude tapes as desired.

NOTE

When the Altitude tape is disabled, the numerical display of the selected altitude remain on. However, an installer can disable and remove the Selected Altitude Fields, and Markers from the display.



Figure 4-25
Data Bar

4.3. Data Bar

The Data Bar presents GPS, Ground Speed (GS), and Barometric Pressure Setting, as shown in **Figure 4-25**. The Data Bar is always present on the display. Invalid or out-of-range Data Bar values are dashed.

1 Ground Speed (GS)

2 Barometric Pressure Setting

4.3.1. Ground Speed

The Ground Speed (GS) comes from a configured GPS navigator and is digitally displayed in the lower left corner of the Data Bar with a value range of 5–999 knots or mph, using the same unit of measurement as the Airspeed Indicator.

4.3.2. Barometric Pressure Setting Display

The Barometric Pressure Setting Field is displayed on the upper right corner of the Data Bar and is pilot-adjustable, as discussed in **Section 4.2.3.1**. When the Altitude Tape is disabled, the Barometric Pressure Setting field remains visible. However, an installer can disable the field and remove it from the display. **Section 4.2.3.1** provides complete information and step-by-step instructions for setting the barometric pressure.

4.4. Navigation Display

The Navigation Display of the E5 Dual EFI, combines a Direction Indicator with a Course Deviation Indicator (CDI) (Figure 4-26).

The Direction Indicator comprises a compass, numerical direction indication, heading bug, Ground Track Marker (when GPS ground track information is available), rate of turn indicator, and aircraft ownership symbol. The CDI is comprised of a selected course pointer, Deviation Scale and indicator, TO/FROM indicators, and selected navigation source label.

- | | |
|---|--|
| <p>1 Magnetic Heading</p> <p>2 Rate of Turn Indicator</p> <p>3 Selected Heading Field</p> <p>4 Ground Track Marker</p> <p>5 Course Pointer</p> <p>6 Heading Bug</p> <p>7 Aircraft Ownership Symbol</p> | <p>8 Course Deviation Scale</p> <p>9 Selected CDI Navigation Source</p> <p>10 Course Deviation Indicator</p> <p>11 TO/FROM/LOC Indicator</p> <p>12 Compass Scale</p> <p>13 Selected Course Field</p> |
|---|--|

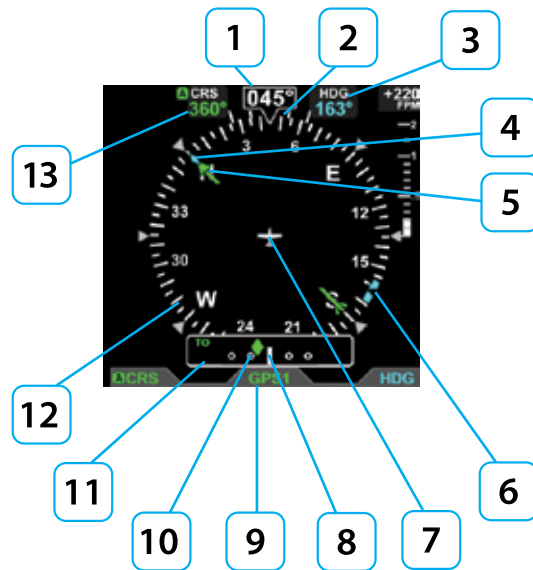

Figure 4-26
Navigation Display

NOTE

The size, shape and location of the Course Pointer, depend on the Compass Mode selected.

Select Compass Type

1. Press the 360/ARC Hot Key (**Figure 4-29**) to alternately select either the 360° or ARC Compass Mode.

The Navigation Display changes and the Hot Key label reflects the currently selected Compass Mode (**Figures 4-30 and 4-31**).



Figure 4-29
360/ARC Hot Key



Figure 4-30
ARC Compass Mode



Figure 4-31
360° Compass Mode



Figure 4-32
Stub Course Arrowhead,
ARC Compass Mode



Figure 4-33
Stub Course Tail,
ARC Compass Mode

4.4.2. Course Pointer

For all Compass Modes, the arrowhead of the Course Pointer aligns with the corresponding value on the compass scale regardless of the aircraft heading. The ARC CDI Course Pointer is described in **Table 4-2**.

COMPASS	DESCRIPTION
ARC CDI	The Course Pointer is shown as a stub arrow or tail whenever the CRS value or its reciprocal falls within the displayable range of the compass scale arc (Figure 4-32 and 4-33).

Table 4-2
ARC Compass Mode Course Pointer Display

4.4.3. TO/FROM Indicator

Each of the Compass Modes has a TO/FROM indicator. The TO/FROM indicator shows whether the aircraft is heading toward a waypoint or radio navaid, or from a waypoint or radio navaid. For each Compass Mode, the TO/FROM indication is slightly different, as described in **Table 4-3**.

COMPASS	DESCRIPTION
360 CDI / ARC CDI	The TO indication is shown as TO on the left side of the Deviation Scale (Figure 4-34). The FROM indication is shown as FROM on the left of the Deviation Scale (Figure 4-35). The LOC indication is shown on the left of the Deviation Scale (Figure 4-36)

Table 4-3
TO/FROM Indicator Description



NOTE

The E5 Dual EFI functions as a legacy CDI when flying a back course. Expect reverse sensing.



Figure 4-37
Course Deviation Indicator, DI Compass Mode



Figure 4-38
Deviation Exceeded, CDI

4.4.4. Course Deviation Indicator and Scale

Selected course deviation is depicted by a Course Deviation Indicator and Scale. Deviation is indicated by positioning the Course Deviation Indicator on the Scale corresponding to the lateral deviation value.



The ARC CDI Compass Mode's CDI and Scale are located at the bottom of the lower display. The indicator is a green diamond, and the Scale is a set of four hollow, white dots with a white index mark at the center (**Figure 4-37**).

When the lateral deviation exceeds the maximum displayable range of 2.5 dots, the Deviation Indicator bar or diamond, as applicable, becomes hollow and darker (**Figure 4-38**).

4.4.5. CDI Navigation Source

When the E5 Dual EFI powers up, the default Selected CDI Navigation Source is the last source selected. The pilot can select from any of the installed navigation sources using the Middle Button. The EFI supports navigation information display from VHF Omni-directional Radio Range (VOR) nav aids, and Global Positioning Systems (GPS). There can only be one GPS Nav/Com and one VHF Nav/Com systems integrated with the E5 Dual EFI.

When integrated GPS/VLOC equipment are installed, the GPSS signal source is provided by the associated GPS whenever the CDI navigation source is selected to either the GPS side or the VLOC side of the integrated GPS/VLOC receiver.

Select the CDI Navigation Source

- Press the CDI Navigation Source Select button until the desired navigation source is displayed above the button (e.g., GPS1, VLOC1) (**Figure 4-39**).

1

CDI Navigation Source Select Button

2

Selected CDI Source Label



Figure 4-39
CDI Source selection and Information

NOTE

For integrated systems, the CDI navigation source label indicates the current operating mode (GPS or VLOC) of the GPS/VHF NAV system.

When an integrated system is selected but not reporting its operating mode, VLOC1 is shown as the Selected CDI Navigation Source.

Refer to the GPS or VHF NAV AFMS for information on the operation of the connected navigation equipment.

NOTE

There are many radio configurations available. Your authorized Aspen Avionics Dealer can explain the configuration used on your aircraft.



Figure 4-40
AUTO CRS



Figure 4-41
AUTO CRS Enabled

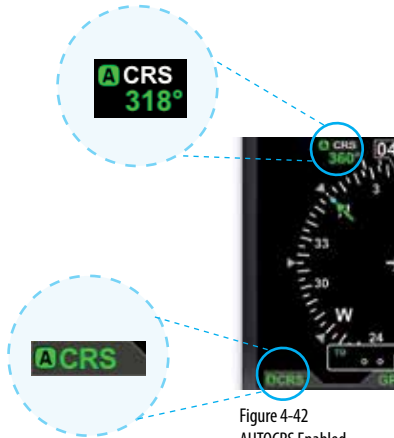

Figure 4-42
AUTO CRS Enabled

4.4.6. Auto Course

The pilot can either use the Auto Course (AUTO CRS) or manually set a CRS value. When the selected CDI Navigation Source is a connected GPS receiver and AUTO CRS is enabled, CRS is not adjustable (current course value is automatically slewed and controlled by the desired track from the GPS). When AUTO CRS is enabled, the CDI navigation source is a GPS, and that system is configured for automatic waypoint sequencing (i.e., not OBS or HOLD modes) then Auto Course Select is active.

Enable Auto Course

1. Press the MENU Button.
2. Rotate the Right Knob to the GENERAL SETTINGS A page.
3. Press the AUTO CRS Menu Key.

The Menu label turns magenta, and the EDIT VALUE label displays above the Right Knob (**Figure 4-40**).

4. Rotate the Right Knob to select ENABLE (**Figure 4-41**).
5. Press the MENU Button to exit.

When AUTO CRS is enabled, the CRS value is set to the desired track output from the CDI Navigation Source. The CRS value is shown in the upper left of the lower display area in green under the CRS label. Additionally, an inverse green A is shown beside the CRS label in the upper left of the lower display area and in the legend above the Left Knob. This indicates that the course is being automatically adjusted (**Figure 4-42**).

Disable Auto Course

1. Press the MENU Button.
2. Rotate the Right Knob to the GENERAL SETTINGS page (**Figure 4-43**).
3. Press the AUTOCRS Menu Key.

The Menu label turns magenta, and the EDIT VALUE label displays above the Right Knob (**Figure 4-44**).

4. Rotate the Right Knob to select DISABLE (**Figure 4-45**).
5. Press the MENU Button to exit.

4.4.7. CDI Selected Course

When the CDI source changes from a GPS source with AUTO CRS to another CDI source, the CRS value reverts to the last set value. When the CDI source is set to a VHF receiver operating in the VOR editing the CRS value adjusts the current selected CRS value. When the CDI source is set to a GPS receiver, and AUTO CRS is disabled, the CRS value may be adjusted.

Select CDI Course

1. Press the Left Knob.

The CRS label above the Left Knob and the Course field are enabled for editing, both rendered in magenta (**Figure 4-46**).

2. Rotate the Left Knob to change the value of the Course field.

Once the CRS value is set, and after 10 seconds of inaction, the CRS field is disabled, and both the label and field are rendered in cyan.



Figure 4-43
Menu, GENERAL SETTINGS



Figure 4-44
Editing AUTO CRS



Figure 4-45
AUTO CRS Disabled



Figure 4-46
CRS Field Enabled for Editing



Figure 4-47
Heading Bug and Selected
Heading Field



Figure 4-48
Selected Heading Bug Outside of
the ARC Compass Scale Range



Figure 4-49
Heading Selected to Edit

4.4.8. Heading Bug

The EFI offers a pilot-selectable Heading Bug. The Heading Bug symbol is positioned on the compass scale according to the Selected Heading Field value (HDG) set by the pilot (**Figure 4-47**).

When the Selected HDG Field value is outside the visible compass scale range in the ARC Compass mode, only a portion of the Heading Bug is shown at the edge of the compass arc, closest to the HDG value (**Figure 4-48**).

When selected for editing, the Heading Bug and the Selected HDG Field value are shown in magenta. Additionally, a dashed magenta line extends from the Ownship Symbol to the Heading Bug, corresponding to the HDG value. When the Heading Bug is SYNCed, the HDG value is set to the current heading.

Set Heading Bug

1. Press the Right Knob.

The HDG label above the Right Knob and the Selected Heading Field are enabled for editing, both rendered in magenta (**Figure 4-49**).

2. Rotate the Right Knob to change the value of the Selected Heading Field.

Once the HDG value is set, and after 10 seconds of inaction, the Selected HDG Field is disabled, and both the Right Knob State and the Selected Heading Field are displayed in cyan.

4.4.9. Aircraft Heading Display

The aircraft heading is displayed in degrees magnetic (Figure 4-50).

If the aircraft's heading is unavailable or invalid, all heading and navigation information, including the CDI is removed and replaced with a single red X covering the entire lower display area, along with the annunciation DIRECTION INDICATOR FAIL (Figure 4-51).

4.4.10. Rate of Turn Indicator

The Rate of Turn Indicator consists of a curved white line originating from the corresponding side of the aircraft heading (i.e., a left turn indication starts on the left side of the index mark) and extends in the direction of the turn along the outer radius of the compass scale. The turn rate indication is provided for both compass modes, 360° (Figure 4-52) and ARC (Figure 4-53).

The Rate of Turn Indicator features tick marks for full and half-standard rate turns (a standard rate turn = 3° per second).

The Rate of Turn Indicator has a range of 0° – 6° per second. When the turn rate exceeds 6° per second, an arrowhead is added to the end of the tape to show that the rate of turn has exceeded the limits of the instrument.



Figure 4-50
Direction of Flight
Numerical Display



Figure 4-51
Direction Indicator Fail



Figure 4-52
Rate of Turn Indicator
(360° Compass Mode)



Figure 4-53
Rate of Turn Indicator
(ARC Compass Mode)

NOTE

The EF1's Rate of Turn Indicator will be removed when operating in DEGRADED MODE.



Figure 4-54
ARC Compass Mode, Ground Track Marker



Figure 4-55
360° Compass Mode, Ground Track Marker

4.4.11. Ground Track Marker

When configured with a GPS that provides ground track data, a Ground Track Marker is displayed on the compass scale to indicate the aircraft's ground track. This marker may be used to compensate for wind drift during flight (Figures 4-54 and 4-55). The Ground Track Marker is removed from the display when ground track data is not available or invalid.

4.4.12. GPS OBS Operation with a EFI and a Mechanical Standby Nav Indicator

When the EFI and a mechanical standby Nav indicator are both connected to an integrated VOR/GPS Navigation system, the standby indicator and the EFI operate normally in all VOR, GPS and localizer modes.

When the GPS OBS mode is selected, the EFI Selected Course (CRS) control commands the GPS OBS course and the mechanical standby nav indicator's OBS course selector is ignored by the integrated navigation system. Deviation indications are shown on both displays. When the EFI is turned off, the course selector on the mechanical standby Nav indicator commands the GPS OBS value.

4.4.13. Course Pointer Operation with Integrated VOR/GPS Navigation Systems

During manual or automatic operation of the integrated system, when transitioning from GPS guidance to VOR or localizer guidance, the course pointer on the E5 Dual EFI should manually be set to the appropriate course.

4.5. Vertical Speed Indicator

When the 360° Compass Mode is selected, the Vertical Speed Indicator (VSI) is rendered on the right side of the Navigation Display, showing a numerical and graphical representations of vertical speed. The VSI shows the change in pressure altitude over time. The graphical display is a white VSI Tape, with the numerical value at the top (Figure 4-56). In either ARC Compass mode, only the numerical value is shown.

The VSI Tape displays rates of $\pm 2,000$ FPM while the numerical value displays rates up to $\pm 9,990$ FPM. When the vertical speed exceeds $\pm 2,000$ FPM, a triangle caps the VSI Tape (Figure 4-57).

The VSI Tape is nonlinear, giving more display area to the 0 to $\pm 1,000$ FPM range than to the $\pm 1,000$ to $\pm 2,000$ FPM range. Tick marks are presented only in the direction of the climb or descent to provide visual cues for trends. The VSI's numerical value, tape, and scale are only shown if the aircraft is climbing or descending more than ± 100 FPM. During level flight in calm air conditions, the tape, scale, and zero reference line are removed from the display. The numerical value is always enabled and shows dashes when vertical rates are out of range. If vertical speed is invalid, the Tape and numerical display are replaced with a red X and the annunciation, VSI FAIL (Figure 4-58).



Figure 4-56
VSI



Figure 4-57
VSI Tape Off-Scale

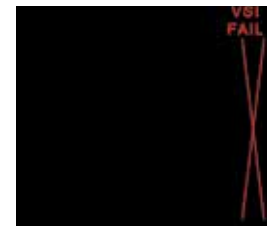

Figure 4-58
VSI Fail – 360° Compass Mode

 **NOTE**

Refer to the autopilot AFMS for information on the operation of the autopilot.

4.6. Autopilot Integration¹

The EFI can connect with many different legacy autopilot systems that are typically found in general aviation aircraft. Autopilot integration is limited to heading and navigation modes.

When connected to an autopilot system that includes Nav couplers, the E5 also acts as the navigation source selector switch to the autopilot. This assures that the navigation information selected for the EFI is the same as that being provided to the autopilot. This arrangement also eliminates the need for external autopilot navigation source selector switches and relays that were previously used to select which navigation radio would be connected to the autopilot. Selection of autopilot modes and mode control is unaffected by the installation of the EFI.

The EFI does not currently provide vertical coupling to barometric references, such as altitude hold, vertical speed, or altitude capture.

See **Section 4.6.2. Typical Autopilot Operation** for more details on EFI operation with the autopilot systems during typical aircraft operations.

1. May require optional ACU

4.6.1. GPS Steering (GPSS)¹

GPS Steering represents a modern approach to flying between flight plan waypoints, and offers many advantages of over traditional methods of flying direct course lines between waypoints.

With traditional point-to-point navigation, the autopilot is provided with desired course and cross-track deviation information associated with the current flight leg. From there, it will maneuver the aircraft to center the needle and track the desired course. The autopilot does not anticipate upcoming course changes, nor can it fly curved flight paths without pilot assistance, and it has to recompute wind corrections following each course change. Upon reaching a waypoint, the pilot must set the course for the next leg (unless AUTOCRS is enabled, see **Section 4.4.6. Auto Course**), and the autopilot will then intercept and track that leg. In this type of operation, the CDI must always be set to the desired course.

With GPSS, the EFI can unlock the GPS Steering capability already available in many models of general aviation GPS navigators. With GPSS, the navigator continuously computes the desired bank angle to track the GPS flight plan, and outputs that information over a digital data bus. The GPS Steering command anticipates upcoming turns; this includes the turn rate and turn initiation point required to roll out centered on the next leg.

Some GPS navigators, such as the Garmin 4xx/5xxW, GTN 650/750 and Avidyne IFD440/550 series of WAAS navigators, even provide GPS Steering commands for complex procedures, such as DME arcs, holding patterns, and procedure turns allowing the autopilot to fly these maneuvers without pilot intervention. Check with your GPS manufacturer to see if your GPS supports these capabilities.



WARNING

GPS Steering is a powerful automation tool that can substantially reduce pilot workload. However, using GPSS safely and effectively requires a thorough understanding of your specific aircraft installation and the interaction between the EFI, your GPS navigator, and your autopilot. Pilot actions required to use GPSS safely can vary significantly depending on the autopilot and GPS navigator installed, especially when used on instrument approaches, especially those with vertical guidance.

It is imperative that pilots new to GPSS gain experience with it in VFR conditions and, ideally, get dual instruction from a CFII who thoroughly understands GPSS and the autopilot and GPS navigator in your airplane before using GPSS on instrument procedures in IMC.

1. May require ACU option

NOTE

Refer to the Aircraft Flight Manual Supplement for your GPS for information about GPSS commands that may be output by that system.

NOTE

When GPSS is selected on the E5 Dual EFI, the autopilot must be in Heading mode to follow the GPSS commands.

NOTE

When GPSS is disabled, the autopilot will follow the Heading Bug.

The EFI translates GPS Steering commands received over a digital data bus into a signal that is compatible with the autopilot Heading channel. Thus, by selecting GPSS Hot Key on the EFI and the Heading mode of the autopilot, the autopilot is able to fly GPSS commands.

If the connected GPS does not provide the required steering commands, the GPSS legend adjacent to the GPSS Hot Key will be rendered in gray, and it will not be possible to enable GPSS with the Hot Key.

Enable/Disable GPSS

1. Press the GPSS Hot Key to alternately enable or disable GPS Steering (**Figure 4-59**).



Figure 4-59
GPSS Hot Key

When GPSS is enabled, and the autopilot is in HDG mode, the autopilot will follow the steering commands from the GPS. A GPSS enabled state will be indicated on the EFI in two locations: 1) the GPSS legend adjacent to the GPSS Hot Key will be shown in inverse green; and 2) the annunciation GPSS1 along with an inverse A, will be shown next to the HDG reference at the top of the Navigation Display, to the right of the Magnetic heading indication (**Figure 4-60**).



Figure 4-60
GPSS Enabled with Autopilot in HDG Mode

When GPSS is disabled, and the autopilot is in HDG mode, the autopilot will follow the EFI Heading Bug. A GPSS disabled state will be indicated on the display in two locations: 1) the GPSS legend adjacent to the GPSS Hot Key will be shown in gray; and 2) the Selected Heading Field will return. (**Figure 4-61**).

When the E5 Basemap navigation source is GPS1, enabling GPSS with the autopilot in HDG mode will cause the autopilot to track the flight plan in GPS1, and GPSS1 will be annunciated by the HDG reference at the top of the Navigation Display. See **Section 4.4.5** for additional information on the relationship among the CDI navigation source and GPSS navigation source.



Figure 4-61
GPSS Disabled and Autopilot in HDG Mode

When using GPSS with a stand-alone VLOC receiver, or with a combined GPS/VLOC navigator (e.g., the GNS-430/530), GPSS will continue to follow the GPS output of that combined navigator, even when VLOC is selected as the EFI Selected CDI Navigation Source. With combined GPS/VLOC receivers, the transition from GPS to VLOC may occur automatically, depending on how that system has been configured by the pilot.

WARNING

It is your responsibility as Pilot in Command to ensure that you are familiar with the operation of all installed equipment. Operation of the EFI in IMC conditions should not be attempted unless you are proficient in its use and operation, as described herein.



Figure 4-62
GPSS Automatically
Disabled — Wings Level Mode

With GPSS enabled on the EFI and the autopilot in HDG mode, the GPSS will steer the autopilot laterally through the flight plan using GPS, even after the GNS-430 CDI automatically switches to VLOC, and the EFI navigation source similarly switches to VLOC.

Several conditions can cause GPSS to be disabled automatically, losing the GPS navigator source, canceling the flight plan, etc.). If this happens, the EFI will send a Wings Level command to the autopilot when in HDG mode, the GPSS Hot Key will annunciate the condition by showing GPSS in inverse amber, and the GPSS# and inverse A annunciation at the top of the Navigation Display will be shown with a red slash. (See **Figure 4-62**). To re-engage GPSS, select a valid GPS navigation source (with valid flight plan or direct-to selection on the GPS navigator), and then press the GPSS Hot Key. If a valid GPSS signal cannot be restored, pressing the GPSS Hot Key will cancel GPSS mode and restore the Heading Bug's output to the autopilot. More detail on these abnormal conditions, and corrective pilot actions, can be found in **Chapter 6, Expanded Emergency and Abnormal Procedures**. See also **Chapter 4, Section 4.7.3. Typical Autopilot Operations**.

4.6.2. Typical Autopilot Operations¹

Whenever the EFI's installed configuration includes connections to GPS, VLOC, and autopilot systems, it acts as a data conduit between the navigators and the autopilot. This enables any compatible navigator to be coupled to the autopilot.

NOTE

With the autopilot in HDG mode, if GPSS is automatically disabled, the autopilot will roll wings level; it will not follow the Heading Bug.

NOTE

Refer to the autopilot systems Aircraft Flight Manual Supplement and/or POH for details regarding use and operation of the autopilot system.

Examples here are provided for reference only, actual operation may vary depending on the autopilot system installed in your aircraft.

1. May require ACU option

 **NOTE**

When GPSS is enabled, the Heading Bug is not coupled to the autopilot. To connect the Heading Bug to the autopilot, disable GPSS with the GPSS Hot Key.

 **NOTE**

The autopilot must be in Heading (HDG) Mode to receive GPSS signals from the E5 Dual EFI.

 **NOTE**

When using an integrated GPS/VLOC navigator, select VLOC or GPS with the CDI source button on the GPS select until the desired CDI Navigation Source is shown on the EFI (See [Section 4.4.5](#).)

HDG Mode Operation – Heading Bug Steering

1. Set the Heading Bug to the desired heading ([Section 4.4.8](#)).
2. Verify that GPSS is not selected.
3. Select the autopilot's Heading (HDG) mode.
4. Engage the autopilot and verify that the autopilot turns the aircraft to the selected heading.

HDG Mode Operation – GPS Steering (GPSS)

1. Couple the EFI CDI to a GPS navigation source with an active flight plan.
2. Enable GPSS by pressing the GPSS Hot Key.
3. Select the autopilot's Heading (HDG) mode.
4. Engage the autopilot and verify that the autopilot turns the aircraft to follow the GPS flight plan.

NAV Mode Operation – VLOC Navigation

1. Using the CDI Source Select button, couple a tuned/valid VLOC radio to the EFI CDI and adjust the Course Pointer (CRS) to a value that will intercept the course.
2. Set the Heading Bug
3. Engage the autopilot in Heading (HDG) mode and verify that the aircraft turns to the desired heading.
4. If your autopilot supports automatic Heading to Navigation mode transitions, arm Navigation capture on the autopilot by selecting its Navigation (NAV) mode. Otherwise, select the autopilot's Navigation (NAV) mode when the autopilot's navigation signal capture criteria are satisfied (see your autopilot AFMS for more information).
5. Monitor the CDI deflection and verify that, upon intercepting the desired course, the autopilot modes transition appropriately and the autopilot tracks the desired course.

NAV Mode Operation – GPS Navigation

1. With a valid flight plan programmed and active in the GPS, use the CDI Source Select button to couple the GPS to the EFI (see **Section 4.4.5.**).
2. If AUTO CRS is disabled, set the Course Pointer to the desired course (CRS) (see **Section 4.4.7.**), or enable AUTO CRS (see **Section 4.4.6.**).
3. With GPSS disabled, set the Heading Bug (see **Section 4.4.8.**) to a value that will intercept the active leg of the flight plan, or enable GPSS via the GPSS Hot Key.
4. Engage the autopilot in Heading (HDG) mode and verify that the aircraft turns to a heading to intercept the active leg of the flight plan.
5. If your autopilot supports automatic heading to nav mode transitions, arm the navigation capture on the autopilot by selecting its Navigation (NAV) mode. Otherwise, select the autopilot Navigation (NAV) mode when the autopilot navigation signal capture criteria are satisfied (see your autopilot AFMS for more information).
6. Monitor the CDI deflection and verify that, upon intercepting the flight plan leg, the autopilot modes transition appropriately and the autopilot tracks the desired course



NOTE

Not all autopilots operate in the manner described here for intercepting courses. See the AFMS for your autopilot installation to understand how to adapt these example procedures to your particular autopilot.

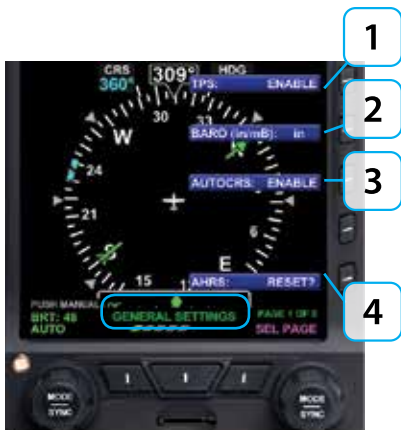

Figure 5-1
GENERAL SETTINGS A

Chapter 5

Customizing the E5 Dual EFI

5.1. Menu Overview

The following tables and figures provide a brief overview of each menu page and its menu options.

KEY DESCRIPTION	OPTIONS
1 Displays Airspeed and Altitude Tapes ¹	DISABLE or ENABLE
2 BARO (in/mB):	BARO (in/mB):
3 Auto Course Select	DISABLE or ENABLE
4 AHRS Reset	Action

Table 5-1
Menu – GENERAL SETTINGS

KEY DESCRIPTION	OPTIONS	
1	VSPEEDS	DISABLE or ENABLE
2	Va	0 to 450 or LOCKED
3	Vbg	0 to 450 or LOCKED
4	Vref	0 to 450 or LOCKED
5	Vr	0 to 450 or LOCKED

Table 5-2
Menu –VSPEEDS A

KEY DESCRIPTION	OPTIONS	
1	Vx	0 to 450 or LOCKED
2	Vy	0 to 450 or LOCKED
3	Vlo	0 to 450 or LOCKED
4	Vle	0 to 450 or LOCKED

Table 5-3
Menu – VSPEEDS B



Figure 5-2
VSPEEDS A



Figure 5-3
VSPEEDS B

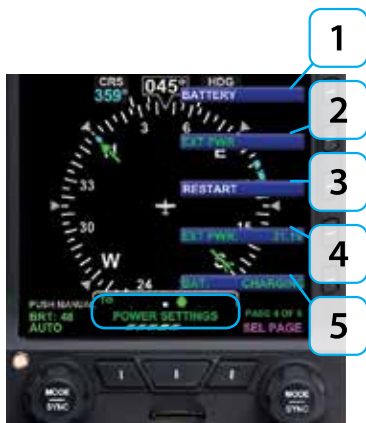

Figure 5-4
POWER SETTINGS

NOTE

For external/battery power control, the legend of the current power source is shown in green; pressing the associated menu key will perform no action. The legend of an available power source is shown in white, and pressing the associated menu key changes input power to that power source.

KEY DESCRIPTION		OPTIONS										
1	Operating from or Switch to Battery Power. Green when current state (Pressing key performs no action). White if selection is possible.	Status or Action										
2	Operating from or Switch to External Power. Green when current state (Pressing key performs no action). White if selection is possible.	Status or Action										
3	Restart or shutdown.	Action										
4	External Power Source Voltage. Displays voltage level of input power.	Status Only										
5	<table border="1"> <thead> <tr> <th>Battery Status</th> <th>Description</th> </tr> </thead> <tbody> <tr> <td>##%</td> <td>Displays battery % charge.</td> </tr> <tr> <td>CHARGING</td> <td>The battery has sufficient voltage and can accept charging, aircraft power is available, and the temperature sensor is within limits (0°C to +55°C).</td> </tr> <tr> <td>FAILED</td> <td>The battery voltage is less than 6 volts; i.e. insufficient for charging.</td> </tr> <tr> <td>READY</td> <td>The connected battery and battery voltage are satisfactory, but the temperature limits (0°C to +55°C) that will permit charging have been exceeded.</td> </tr> </tbody> </table>	Battery Status	Description	##%	Displays battery % charge.	CHARGING	The battery has sufficient voltage and can accept charging, aircraft power is available, and the temperature sensor is within limits (0°C to +55°C).	FAILED	The battery voltage is less than 6 volts; i.e. insufficient for charging.	READY	The connected battery and battery voltage are satisfactory, but the temperature limits (0°C to +55°C) that will permit charging have been exceeded.	Status Only
	Battery Status	Description										
	##%	Displays battery % charge.										
	CHARGING	The battery has sufficient voltage and can accept charging, aircraft power is available, and the temperature sensor is within limits (0°C to +55°C).										
FAILED	The battery voltage is less than 6 volts; i.e. insufficient for charging.											
READY	The connected battery and battery voltage are satisfactory, but the temperature limits (0°C to +55°C) that will permit charging have been exceeded.											

Table 5-4
Menu – POWER SETTINGS

KEY DESCRIPTION		OPTIONS
1	Main Application Processor Software Version	Status Only
2	Input Output Processor Software Version	Status Only
3	Unit Serial Number	Status Only

Table 5-5
Menu – SYSTEM STATUS



Figure 5-5
SYSTEM STATUS

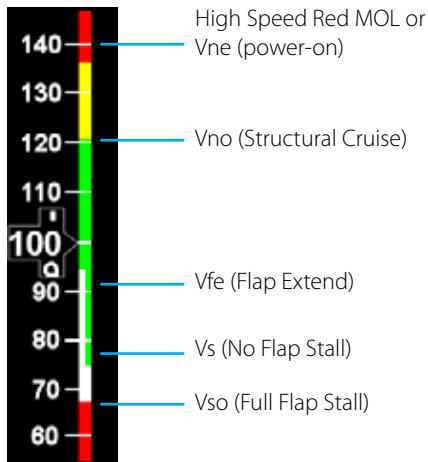

Figure 5-6
Vspeeds

5.2. Configuring Vspeeds

Vspeeds (**Figure 5-6**) are used to designate different operating speeds of the aircraft and are defined in **Table 5-6**.

Vspeed	DEFINITION	PRE-SET BANDS	ADJUSTABLE TEXT LABELS	PRE-SET MARKERS
Vne	Never exceed	●		● (Red Line)
Vno	Maximum structural cruising speed	●		
Vfe	Maximum full flap extension speed	●		
Vs	No flap stall	●		
Vso	Stall speed in landing configuration	●		
Va	Design maneuvering speed		●	
Vbg	Best glide		●	
Vr	Rotation speed		●	
Vref	Landing reference speed		●	
Vx	Best angle of climb		●	
Vy	Best rate of climb		●	
Vle	Maximum landing gear extended speed		●	

Vspeed	DEFINITION	PRE-SET BANDS	ADJUSTABLE TEXT LABELS	PRE-SET MARKERS
Vlo	Maximum landing gear operating speed		●	
Vmc	(Multi-engine) Single-engine minimum control airspeed			● (Red Line)
Vyse	(Multi-engine) Best single-engine rate of climb			● (Blue Line)
◁	Maximum initial flap extension speed			●

Table 5-6
Vspeed Definitions

The EFI uses color speed bands, color speed markers, and textual labels to help the pilot recall Vspeed settings and limits. The speed band markings are determined by the Federal Regulations and correspond to the aircraft operating speeds that are identified in the Aircraft Flight Manual. They have a range between two speeds that are pre-set at installation as outlined in **Table 5-7** and shown in (**Figure 5-7**).

Speed markers are also pre-set during installation, indicating important aircraft-specific speeds, where applicable. The textual Vspeed labels are made pilot adjustable or locked during the installation.

NOTE

Setting the value of the white triangle, Vyse, and Vmc markers to zero (0) during installation disables the markers. Setting any of the adjustable Vspeed values to zero (0) disables the associated label.

NOTE

On aircraft without flaps, the white band is disabled, and the green band is shown full width, as there isn't an applicable Flap Extend (V_{fe}) or Full Flap Stall (V_{s0}) speed. These two speeds are set to the same speed as the No Flap Stall (V_s) speed. This gives the white band a value of zero, effectively disabling it.



Figure 5-7
Speed Bands

BAND COLOR	SPEED RANGE	
Red or Barber Pole Band (High Speed)	V_{ne}/MOL	Never Exceed/Maximum Operating Limit
Yellow or Clear	$V_{no} - V_{ne}$	Caution Range
Green, Clear or White	$V_s - V_{no}$	Normal Operating Range
White or Clear	$V_{so} - V_{fe}$	Flap Operating Range
Red	V_{so} (Bottom of tape)	Disabled on the ground and during takeoff

Table 5-7
Speed Band Ranges

NOTE

The color speed bands and color speed markers on the E5 Dual EFI Airspeed Tape are configured to match the certified mechanical airspeed indicator.

On aircraft with flaps, setting the upper and lower thresholds of the white and/or yellow bands to the same value disables the applicable band. When disabled, the band does not display.

When using the Vspeed textual markers, the pilot must first ENABLE the display of the markers and then set values for each Vspeed. The value range for Vspeed textual markers is 0 – 450 or LOCKED. The default setting is 0 unless previously set to another value. When the value is 0, the Vspeed is individually disabled, and the marker is not shown on the Airspeed Tape. Once the values are set, the pilot can choose to disable all the Vspeed textual markers to declutter the Airspeed Tape.

Display or Hide the Vspeed Textual Markers on the Airspeed Tape

1. Press the MENU Button.
2. Rotate the Right Knob to the VSPEEDS A Menu page (**Figure 5-8**).
3. Press the VSPEEDS Menu Key.
The Menu label turns magenta, and the EDIT VALUE label displays above the Right Knob (**Figure 5-9**).
4. Rotate the Right Knob to select ENABLE or DISABLE (**Figure 5-10**).
ENABLE will display the Vspeeds on the Airspeed Tape and DISABLE will hide the Vspeeds to declutter the Airspeed Tape
5. Press the MENU Button to exit.



Figure 5-8
VSPEEDS A



Figure 5-9
Editing VSPEEDS



Figure 5-10
VSPEEDS Disabled



Figure 5-11
VSPEEDS A



Figure 5-12
Editing Va Vspeed



Figure 5-13
Va Vspeed Set With New Value

Set Textual Vspeed Labels

1. Press the MENU Button.
2. Rotate the Right Knob to the appropriate Vspeed Menu page (**Figure 5-11**).
3. Press the appropriate Vspeed Menu Key.
The Menu label turns magenta, and the EDIT VALUE label displays above the Right Knob (**Figure 5-12**).
4. Rotate the Right Knob to the desired value (**Figure 5-13**).
5. Select another Menu Key to edit another Vspeed or press the MENU Button to exit.

NOTE

A typical installation sets the Airspeed Textual Markers to UNLOCKED, allowing the pilot to edit the indicated Vspeed labels. If the Vspeed setting was LOCKED during installation, no pilot adjustment is allowed.

5.3. LCD Brightness Control

The LCD brightness of the EFI operates in either of two modes, Automatic or Manual. The LCD brightness range is displayed as a value from 1–100, displayed above the Left Knob.

LCD MODE	DESCRIPTION
AUTOMATIC BRT AUTO	LCD backlight intensity is automatically adjusted based on the ambient lighting conditions sensed by the Automatic Dimming Photocell (Figure 5-14). When using the auto-brightness, the maximum brightness level is 70%.
MANUAL BRT ADJUST	Allows the pilot to adjust the LCD backlight intensity. (Figure 5-15) from 1–100%.

Table 5-15
Brightness Control

Change Brightness Mode

1. Press the MENU Button.
2. Press the Left Knob to select the desired LCD Brightness Control mode, either Automatic (BRT AUTO) (**Figure 5-14**), or Manual (BRT ADJUST) (**Figure 5-15**).
3. Press the MENU Button to exit.

Adjust Display Brightness Manually

1. Switch to manual LCD Brightness Control mode (BRT ADJUST) (**Figure 5-15**).
2. Rotate the Left Knob clockwise to increase the display brightness or counterclockwise to decrease the display brightness. The BRT: value changes accordingly.
3. Press the MENU Button to exit and retain the selected brightness level.



Figure 5-14
Display Brightness in BRT AUTO Mode

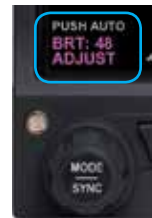

Figure 5-15
Display Brightness in BRT ADJUST Mode

NOTE

When the EFI is operating on the internal battery, the maximum brightness level is capped at 40% in automatic mode and 70% in manual mode to preserve battery operating time.

NOTE

To facilitate cooling of the display unit, when the backlight temperature is greater than or equal to 70°C, the display brightness level is limited to 30% in automatic mode and 70% in manual mode. The limits are removed when the display temperature drops below 60°C.

Chapter 6

Expanded Emergency and Abnormal Procedures

This section supplements and provides an expanded description of the emergency and abnormal procedures included in the FAA-approved Aircraft Flight Manual Supplement. The information provided here is intended to provide additional background information to enhance the pilot's understanding of the emergency and abnormal conditions and the associated procedures provided in the AFMS. This pilot guide is provided for supplementary purposes only. The approved cockpit reference for in-flight use is the AFMS. Both the Pilot Guide and the AFMS must be immediately available to the pilot at all times in flight. In the event of any conflict between this document and the FAA-approved AFMS, the AFMS instructions must be followed.

6.1. Pitot/Static System Blockage

A pitot line blockage will result in the airspeed indicator behaving like an altimeter when the aircraft's altitude changes, and it will not respond to airspeed changes. A pitot line blockage can also affect the EFI's attitude indication.

A static line blockage will result in altitude remaining fixed and a zero vertical speed despite aircraft pitch and/or power setting changes. In addition, IAS indications will be incorrect if the static line is blocked. Errors will typically be noticed during climbs or descents. When descending, ambient pressure increases which will result in the indicated airspeed reading more than the actual airspeed. The opposite effect will be observed in a climb. A static line blockage can also affect the E5 Dual EFI's attitude indication.

Indication of an obstructed pitot system is provided when the E5 Dual EFI's indicated airspeed is less than 30 KIAS (35 mph) and GPS ground speed is greater than 50 kts (58 mph). Initially a "CROSS CHECK ATTITUDE" annunciation will appear as IAS bleeds off. Then an "ATTITUDE DEGRADED" annunciation appears above the aircraft reference symbol (**Figure 6-1**). At this point the IAS part of the AHRS solution is replaced by GPS ground speed. Both the attitude and directional gyro functions of the E5 will continue to function during normal IFR type maneuvering. However, both the Rate of Turn and Slip indicators will be removed. If there is a subsequent failure of the GPS system, then attitude and heading instruments are replaced with red Xs and textual annunciations to indicate their failure. In this case, an amber CHECK PITOT HEAT annunciation accompanies the ATTITUDE FAIL annunciation. When the pitot obstruction is subsequently removed and indicated airspeed \geq 30 KIAS (35 mph), the CHECK PITOT HEAT annunciation will be removed in 15 seconds. This indicates that the EFI is performing an automatic AHRS reset in the background. No pilot action is required to reset the system.



Figure 6-1
Degraded Mode

Blocked Pitot or Static Line Suspected

1. Turn Pitot heat ON
2. Open the Alternate Static Source
3. Refer to alternate, airspeed, altitude, and heading sources for primary flight information
4. Consider exiting IMC
5. Land as soon as practicable

6.1.1. Identifying and Handling Suspected Pitot and/or Static System Failures

Blocked pitot and/or static system ports will degrade the EFI's attitude solution. Therefore, the pilot must be especially vigilant about verifying proper operation of the pitot and static systems both before and during flight.

It is important to check the pitot tube and static system ports, and to verify pitot heater performance, as part of a thorough pre-flight inspection, especially when anticipating flight in low IMC.

On takeoff roll, it is good practice to note and call out "airspeeds alive" when the airspeed indicators (both primary and backup) begin moving and to compare and call out readings at a pre-determined airspeed close to, but before rotation speed (e.g. "60 knots cross check"), consciously noting the performance on each takeoff. If the airspeed indicators do not come "alive" when they usually do or whenever there is a significant difference between the primary and backup indicators and sufficient runway is remaining, aborting the takeoff may be a prudent decision. Follow the Flight Manual procedures for your aircraft.

On the initial climb-out after takeoff, it is also good practice to note and call out passing through a pre-determined altitude above ground level (AGL) a couple of minutes after takeoff and ideally before entering the clouds (e.g., "2,000 feet"). If your primary and backup instruments are not showing the altitude and airspeed you normally expect to see at that point, you might have partially blocked static system ports. This AGL check and call-out is also a good time to verify that no fuel is siphoning out from the fuel caps, etc. If indications suggest a static system blockage, try switching to an alternate static air source and consider landing to correct the problem.

In flight, if airspeed or altitude anomalies consistent with an obstructed pitot or static line are observed, the pilot should recognize that the EFI's attitude indication will soon be degraded. If in IMC, immediately turn pitot heat ON if icing is suspected.

If the pitot tube becomes blocked in flight, the most common cause is icing. In-flight indications of a blocked pitot tube are typically:

- 1) All airspeed indicators incorrectly show zero (or close to zero);
or
- 2) Airspeed in level flight does not change in response to changes in power or drag and airspeed indications act like an altimeter (decreasing in a descent and increasing in a climb, exactly the opposite of normal behavior).

Airspeed going to zero is by far the most common symptom of a blocked pitot tube.

If you see either of these indications of a blocked pitot tube, the first thing to do is turn on the pitot heat to remove any ice blockage. This will quickly restore the normal attitude and airspeed indications on the EFI systems (it takes about 40 seconds to recover after the pitot pressure is restored).

If in flight you suspect blocked static ports (probably due to icing), try switching to the alternate static air source. If the static air sources are blocked, recognize that the readout from the transponder and reports from ATC will be in error because of the blocked static system.

In the event of a pitot/static system failure, the EFI will continue to provide accurate attitude and heading solutions during typical IFR type maneuvering to include holds and both precision and non-precision type approaches.

If GPS altitude is available on your GPS navigator, become familiar with how the GPS altitude is displayed. Although it can be in error, it might be your only source of altitude information (WAAS GPS altitude is reasonably accurate).

6.2. Frequent or Persistent CROSS CHECK ATTITUDE Annunciation

Refer to alternate airspeed, altitude, and heading sources for primary flight information. Consider the following:

CROSS CHECK ATTITUDE

1. Turn Pitot heat ON.
2. Consider exiting IMC.
3. Land as soon as practicable

For a detailed explanation of when and why the EFI may display a CROSS CHECK ATTITUDE annunciation, either momentarily or persistently, *see Chapter 4, Section 4.1. Air Data, Attitude and Heading Reference System (ADAHRS).*

6.3. Difference Detected Between the E5 Dual EFI and Mechanical Indicators

Once diagnosed, ensure the correct source is the only one referenced during the remainder of the flight.

Compare Alternate Sources of Available Airspeed and Attitude

1. Compare all available sources of airspeed, and attitude information to diagnose a faulty indicator.
2. Consider exiting IMC.
3. Land as soon as practicable .



Figure 6-2
Powering Off the E5 Dual EFI

6.4. Abnormal Shutdown Procedure

The E5 Dual EFI is typically powered through a master switch that is connected to the aircraft's bus. Normally, the EFI will power down when the EFI Master switch is turned OFF or when aircraft power is removed when on the ground. To force the display to power down, the following procedures are provided.

Shutdown E5 Dual EFI (on ground)

1. E5 Dual EFI Master switch OFF
2. Press and hold the REV Button until the display turns off (**Figure 6-2**)

Or

1. Press the MENU Button.
2. Rotate the Right Knob to the POWER SETTINGS Menu page
3. Press the SHUT DOWN Menu Key. The power down sequence initiates, and a power down message displays

A powering off annunciation displays indicating that the unit will shut down in 5 seconds. The pilot can press any control to abort the power-down sequence.

Power On Manually

- Press and hold the REV Button until the E5 Dual EFI powers on.

6.5. Loss of Aircraft Electrical Power

In the event that aircraft generated power is degraded or fails, the E5 Dual EFI will automatically switch to its own dedicated battery (**Figure 6-3**). When continued safe operation depends on the EFI, **UNRESTORABLE LOSS OF EXTERNAL POWER IS AN EMERGENCY SITUATION**. The aircraft should divert to the nearest suitable airport.

Loss of or Degraded Aircraft Power or ON BAT Annunciation

1. Electrical SystemFollow AFM procedures to restore power
2. If unable to restore powerLand as soon as possible

The internal battery will normally provide between 30-60 minutes of operation at approximately 20°C and warmer. At extreme cold temperatures, operation of the internal battery is not assured.

When on battery the auto backlight intensity level defaults to 40% and manual backlight intensity is limited to 70%. Changing the backlight intensity will affect the battery duration, which is reflected in the % remaining indication.

A fully charged battery will indicate a charge level of 99% for some time before beginning to discharge. The charge level will steadily decrease when below 95%, with a slight acceleration as the battery nears 0%.

The “ON BAT” annunciation, along with the estimated battery charge remaining, is displayed whenever the system is operating on battery.



Figure 6-3
Battery Charge Remaining

6.5.1. Overvoltage Protection

In the event of an overvoltage condition in the aircraft's electrical system, (greater than 33 volts) the EFI will automatically switch to its battery power and continue to operate without any pilot action. Operation from the aircraft electrical system will not be possible while the overvoltage condition is present. When aircraft power decreases below 33 volts, pilot action is required to manually switch from the EFI battery power.

Restore Aircraft Power to the EFI

1. Press the MENU Button and rotate the Right Knob to the POWER Settings page
2. Press the EXT PWR Menu Key
3. Press the MENU Button to exit

 **WARNING**

When fully charged, the internal battery will power the E5 Dual EFI to provide ADAHRS for a minimum of 30 minutes in temperature extremes and much longer in normal operating temperatures (Refer to the AFMS). When continued safe operation depends on the EFIs primary flight data, **UNRESTORABLE LOSS OF EXTERNAL POWER IS AN EMERGENCY SITUATION**. The pilot should follow the electrical failure checklist in the Aircraft Flight Manual land as soon as possible.

 **CAUTION**

During situations where a high electrical demand is placed on the aircraft electrical system, electrical transients that cause aircraft voltage to drop below 9.0V momentarily or 12.3V for 2 minutes (14V electrical system) or 18.0V momentarily or 24.6V for 2 minutes (28V electrical system) will cause the EFI display to automatically switch to its internal battery.

This will be accompanied by an ON BAT annunciation.

The ON BAT annunciation should extinguish shortly after the electric transient demand goes away. If the ON BAT annunciation does not extinguish, then an aircraft power source failure has most likely occurred.

 **NOTE**

When operating on the internal battery, the display backlight intensity is limited to a value of 70.

 **NOTE**

Setting the brightness to a value of greater than 40% will reduce the battery operation time to less than 30 minutes.

NOTE

When airborne, if the EFI's input voltage is below the 12.8V (14V Electrical System) or 25.6V (28V Electrical System) automatic battery transition threshold, and EXT PWR is selected through the POWER SETTINGS Menu, the EFI will automatically remain connected to its internal battery.



Figure 6-4
External Power Voltage Status



Figure 6-5
Battery Status

6.6. Power Override

In the event that the pilot wishes to override the EFI's automatic power configuration, proceed as follows:

Power Override

1. MENU“POWER SETTINGS” Page

To switch FROM aircraft power to Internal Battery:

2. “BATTERY” LINE SELECT KEYPRESS

To switch FROM internal Battery TO aircraft power:

3. “EXT PWR” LINE SELECT KEYPRESS

View External Voltage Status

1. Press the MENU Button.
2. Rotate the Right Knob to the POWER SETTINGS Menu displays.
3. The EXT PWR Menu Key (**Figure 6-4**) displays the external power voltage.
4. Press the MENU Button to exit.

View Internal Battery Status

1. Press the MENU Button.
2. Rotate the Right Knob to the POWER SETTINGS Menu displays.
3. The BAT Menu Key (**Figure 6-5**) displays the current Battery Status as either Charging or a Percentage of Charge.
4. Press the MENU Button to exit.

6.7. In-Flight AHRS Reset

If the attitude pitch or roll data become invalid, a red X and the textual annunciation of ATTITUDE FAIL replaces the Attitude Indicator, and all aircraft roll, pitch, and slip information is removed from the Attitude Display (**Figure 6-6**). Use alternate, mechanical flight instruments for primary flight information and reset the AHRS as soon as possible.

During the In-Flight AHRS Reset, the aircraft should not be subjected to excessive turn rates. Typical in-flight Resets will take approximately 30 seconds, but can take longer if the reset is initiated while banked or maneuvering.



Figure 6-6
Attitude Failure



NOTE

When the AHRS is reset in flight, it performs an abbreviated initialization. The AHRS Reset is considered complete when the attitude and heading is once again displayed, stable, and correct with respect to the horizon or standby attitude indicator.



Figure 6-7
AHRS Reset Menu Key

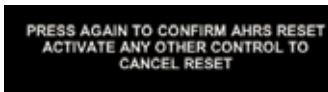

Figure 6-8
AHRS Reset Confirmation Message

NOTE

Pressing any other key, button, or knob cancels the AHRS reset and clears the confirmation message.

Perform an In-Flight AHRS Reset

1. Maintain straight and level flight.
2. Consider exiting IMC.
3. Fly by visual reference or by other instruments.
4. Disconnect the autopilot.
5. Press the MENU Button.
6. Rotate the Right Knob to display the GENERAL SETTINGS A Menu page.
7. Press the AHRS RESET? Menu Key (**Figure 6-7**).
A confirmation message displays, prompting the user to confirm the reset request (**Figure 6-8**).
8. Press the AHRS Menu Key again to confirm the AHRS reset. The AHRS reset is performed, and the confirmation messages clears.
9. Press the MENU Button to exit.

6.8. GPSS Operation, Annunciations, and Autopilot Modes¹

The E5 Dual EFI offers GPSS. Four modes, Enable, Disable, Unavailable and Coast (Wings Level), are possible and annunciated in the Navigation Display. When enabled, the configured GPS source passes GPSS as the heading input to a configured autopilot. When engaged, a configured autopilot will interpret GPSS commands as heading inputs and follow the active GPS flight plan, including anticipated turns, if provided. The GPSS Enabled mode is indicated by a green GPSS Hot Key label and a GPSS1 with an inverse A placed next to the Selected Heading Field to describe the source (Figure 6-9).

If GPSS is enabled and the GPS source is lost or changed, the GPSS mode automatically changes to the Wings Level mode and annunciates as shown in Figure 6-10.



Figure 6-9
Operating in GPSS Mode

NOTE

When using GPSS with combined GPS / VLOC navigators (e.g. GNS 430/530), VLOC may be selected as the navigation source while GPSS is engaged. To avoid confusion, note the EFI Selected CDI Navigation Source controls the CDI and the autopilot's navigation and approach modes when engaged. GPSS reflects the heading commands required to navigate the active flight plan leg and controls the autopilot's heading mode when engaged. Complete understanding of autopilot mode functions and their proper selection is recommended.



Figure 6-10
GPSS in Wings Level Mode

1. May require ACU option



Figure 6-11
GPSS Disabled

The Wings Level mode removes roll steering inputs to the autopilot, causing the aircraft to roll wings level, and displays a red slash through the annunciated A HDG and GPSS# source. The amber GPSS Hot Key label requires pilot action. If this occurs, do the following:

When GPSS Automatically Changes to Wings Level Mode

1. Check the configured GPS source.
2. Check the Selected CDI Navigation Source.
3. If the selected GPSS source is restored or changed and GPSS is still desired, press the GPSS Hot Key to activate GPSS (The GPSS Hot Key label turns inverse green).

Disable GPSS

1. Adjust the EFI HDG bug as desired.
2. Check or set the Autopilot Control Panel modes as desired.
3. Press the GPSS Hot Key until the Hot Key label turns gray (**Figure 6-11**).







NOTE

When the GPSS is enabled and the autopilot is engaged in the Heading (HDG) mode, disabling the GPSS will cause the autopilot to follow the HDG Bug.

NOTE

The configured GPS source must provide an active flight plan (or Direct-To waypoint) for GPSS to remain engaged or to be restored.

6.9. Warning, Caution, and Advisory Summary

 WARNINGS		
 <p>Figure 6-12 Battery Countdown</p>	 <p>Figure 6-13 Battery Charge Remaining</p>	<p>Presented when the EFI is operating on the internal battery. The countdown timer begins at 15 seconds and is then replaced by the ON BAT annunciation with the battery's % charge remaining.</p> <div style="background-color: #e0f2e0; padding: 10px; border: 1px solid #ccc;"> <p> NOTE <i>If the battery temperature is less than 0° C, the countdown timer will begin at 10 minutes.</i></p> </div>
 <p>Figure 6-14 Attitude Fail</p>	 <p>Figure 6-15 Direction Indicator Fail</p>	<p>Presented when the EFI has determined that the associated function is invalid or failed and should not be used. The data is removed from the display and replaced by a red X over the affected display feature.</p>

 **WARNINGS**

Figure 6-16
Chevrons indicate Pitch Down



Figure 6-17
Chevrons indicate Pitch Up

When the Attitude Indicator display extreme pitch up or extreme pitch down attitudes, the red chevrons indicate the direction to restore level flight.

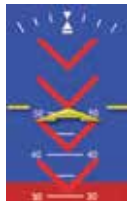
Table 6-1
Warning Annunciations

CAUTION

Figure 6-18
Cross Check Attitude

Presented when the EFI AHRS internal integrity monitor determines that attitude is potentially degraded. When a CROSS CHECK ATTITUDE annunciation is presented, the pilot should cross check attitude, airspeed, and altitude indications with other sources of primary flight information.



Figure 6-19
Check Pitot Heat

The CHECK PITOT HEAT annunciation accompanies the ATTITUDE FAIL annunciation and is presented when the software detects an obstruction in the pitot system that could potentially degrade the attitude solution. This annunciation is removed when the detected condition is resolved, which would be followed by an automatic AHRS reset. A GPS is required for this monitor to be enabled.

 **CAUTION**

Figure 6-20
GPS Invalid

Presented when a configured GPS source's data is invalid or unavailable.



Figure 6-21
Attitude Degraded

Presented to indicate that the EFI is using GPS Ground Speed vice IAS as part of the AHRS solution. Recommended action is to check for PITOT/STATIC blockage.



Figure 6-22
GPSS Source Lost/Changed

Presented when the previously enabled and valid GPSS source is lost or has changed. Indicates the GPSS Wings Level mode¹.

¹ May require ACU option

ADVISORY



Figure 6-23
REV Button Off

Presented when the REV Button is pressed.



Figure 6-24
GPSS On

Presented when GPSS is enabled and the GPS source is valid. This also indicates the autopilot heading source¹.

1. May require ACU option

 **ADVISORY**

Figure 6-25
Navigation Source Invalid or Unavailable

A horizontal red line through the Selected CDI Navigation Source indicates that the data from the source is invalid or unavailable.



Figure 6-26
GPSS Unavailable

GPSS Hot Key label with a blue background and gray letters indicate that the GPSS is unavailable.

Table 6-3 Advisory Annunciations

Chapter 7

Appendices

7.1. Operating Limitations

Refer to the latest version of the [Airplane Flight Manual Supplement \(AFMS\)](#), Aspen Avionics document 900-00008-001 for the limitations that apply to your specific aircraft installation.

The AFMS and this Pilot's Guide must be carried in the aircraft and be immediately available to the pilot while in flight.

7.2. Software Versions and Serial Number

The system software versions for the Main Application Processor (MAP), the Input-Output Processor (IOP), and the unit Serial Number (S/N) are recorded in the SYSTEM STATUS page of the Menu.

The ACU software version and serial number are recorded on a label affixed to the ACU unit.



NOTE

*To view the software version, press the MENU Button and rotate the Right Knob to the Systems Status page. The "MAP VER:" (Main Application Processor Version) displays the software version your unit is operating (see **Figure 7-1**).*



Figure 7-1
View Main Application Processor
Software Version



Figure 7-2
View Input/Output Processor
Software Version



Figure 7-3
View Unit Serial Number

View the Main Application Processor Software Version

1. Press the MENU Button.
2. Rotate the Right Knob to the SYSTEM STATUS Menu page.
3. The MAP VER Menu Key displays the current Main Application Processor Software Version (**Figure 7-1**).
4. Press the MENU Button to exit.

View the Input/Output Processor Software Version

1. Press the MENU Button.
2. Rotate the Right Knob to the SYSTEM STATUS Menu page.
3. The IOP VER Menu Key displays the current Input/Output Processor Software Version (**Figure 7-2**).
4. Press the MENU Button to exit.

View the Primary Flight Display Unit's Serial Number

1. Press the MENU Button.
2. Rotate the Right Knob to the SYSTEM STATUS Menu page.
3. The S/N Menu Key displays the unit's serial number (**Figure 7-3**).
4. Press the MENU Button to exit.

7.3. Specifications

7.3.1. E5 Dual Electronic Flight Instrument (EFI)

GENERAL SPECIFICATIONS	
Width	3.50 in. (Measured at Bezel)
Height	7.00 in. (Measured at Bezel)
Can Depth	4.15 in. (Rear of Bezel to Rear of Can)
Overall Depth	6.35 in. (Knob to Rear Pressure Fitting)
Weight	2.9 lbs. (with Mounting Bracket)
Display Type	6.0 in. Diagonal TFT Active Matrix LCD (400x760)
Display Colors	16M
Face	Anti-Reflective Coated Glass
Backlight	High Intensity White LED
Rotary Knobs	Optical Encoder with Momentary Press
Dimming	Manual & Automatic (Front Bezel Mounted Sensor)
OPERATIONAL SPECIFICATIONS	
Operating Temp	-20°C to +70°C
Storage Temp	-55°C to +85°C
Max Un-Pressurized Operating Altitude	35,000 ft.
Max Pressurized Operating Altitude	55,000 ft.
Cooling	Integral Fan
Max Humidity	95% at 50°C

Input Voltage	+8 to +32 Volts DC
Max Current	2.4 Amps @ 28 VDC
	4.8 Amps @ 14 VDC
I/O SPECIFICATIONS	
ARINC 429 Inputs	5
ARINC 429 Outputs	1
RS-232 Inputs	5
RS-232 Outputs	3
Pitot / Static	Quick Connect
CERTIFICATION SPECIFICATIONS	
Software	ASTM F3153-15
Environmental	RTCA DO-160E
Categories	See Environmental Qualification Sheet found in the Installation Manual.

Table 7-1
E5 Dual Electronic Flight Instrument (EFI) Specifications

7.3.2. Remote Sensor Module (RSM)

Width	2.65 in.
Length	4.40 in.
Height	1.00 in.
Weight	0.2 lbs.
Input Voltage	Provided by EFI
Max Current	Included in EFI Current

Table 7-2
Remote Sensor Module (RSM) Specifications

7.3.3. Analog Converter Unit (ACU)

Width	5.75 in. (including mounting flange)
Length	4.30 in. (including connector)
Height	1.60 in. (including mounting flange)
Weight	0.8 lbs.
Input Voltage	+10 to +32 VDC
Max Current	0.5 Amps @ 28 VDC 1.0 Amps @ 14 VDC
Interfaces	ARINC-429 and RS-232

Table 7-3
Analog Converter Unit (ACU) Specifications

7.3.4. Operational Specifications

Airspeed Range	Minimum displayed airspeed	20 KIAS
	Maximum displayed airspeed	500 KIAS
Altitude Range	Minimum displayed altitude	-1,600 ft. MSL
	Maximum displayed altitude	51,000 ft. MSL
Vertical Speed Range	Maximum displayed vertical speed rates (tape)	+/-2,000 fpm
	Maximum displayed vertical speed rates (numerical value)	+/- 9,990 fpm
Turn Rate	Maximum displayed turn rate	6.0 °/second
Barometric Pressure Correction Range	28.10 to 30.99 In Hg (946 to 1049 mB)	
Internal Battery	Minimum operating time while on internal battery	30 minutes ¹

Table 7-4
Operational Specifications

7.4. Glossary

°C	Degrees Celsius	AWOS	Automated Weather Observation System
°F	Degrees Fahrenheit	Back Course	Localizer back course approach where the signal on the back side of the localizer is used for alignment to the runway opposite of normal localizer alignment.
Accuracy	Estimated position accuracy in feet or meters	Battery Time	The time remaining on the battery before it is fully discharged.
A/D	Analog to Digital	BC	Back Course
AC	Alternating Current	Bearing	The compass direction from the current position to the destination.
ACU	Analog Converter Unit	BP	Bearing Pointer
ADC	Air Data Computer	Calibrated Airspeed	Indicated airspeed corrected for installation and instrument errors.
ADI	Attitude Director Indicator	CDI	Course Deviation Indicator
AFMS	Airplane Flight Manual Supplement	CFR	Code of Federal Regulations
AGL	Above Ground Level	CM	Configuration Module
AHRS	Attitude Heading Reference System	Comm	Communication radio
AI	Attitude Indicator	Course	The route taken from the starting position to destination.
AIM	Aeronautical Information Manual	Course to Steer	The recommended direction to steer in order to reduce cross-track error and return to the course line.
AIRMET	Airman's Meteorological Information	Cross Track	The perpendicular distance, left or right, away from the selected course.
Altitude	Elevation above mean sea level		
APPR	Approach		
APT	Airport		
ARC	Partial Compass Rose, arc format (100°)		
ARINC	Aeronautical Radio, Inc.		
ATC	Air Traffic Control		
ATIS	Automatic Terminal Information Service		

Crosstrack Error	The distance the aircraft is off the desired course.	EFIS	Electronic Flight Instrument System
CRS	Course	Elevation	The height above mean sea level.
CTS	Course to Steer	ETSO	European Technical Standard Order
DC	Direct Current	FAA	Federal Aviation Administration
Decision Height	A specified height or altitude in the precision approach at which a missed approach must be initiated if the required visual reference to continue the approach has not been acquired. This allows the pilot sufficient time to safely reconfigure the aircraft to climb and execute the missed approach procedures while avoiding terrain and obstacles.	FAF	Final Approach Fix
		fpm	Feet Per Minute
		ft	Feet
		GPS	Global Positioning System
		GPSS	GPS Steering
		Ground Track	see Track
		Ground Speed	The velocity that the aircraft is travelling relative to a ground position.
Deg	Degree	GS	Glide Slope or Ground Speed
Desired Track	The desired course between the active “FROM” and “TO” waypoints.	Heading	The direction an aircraft is pointed, based upon indications from a magnetic compass or a properly set directional gyro.
DH	Decision Height		
Distance (Next)	The great circle distance from current location to a Go To destination or the final waypoint in a route.	Hg	Mercury
		HSI	Horizontal Situation Indicator
DME	Distance Measuring Equipment	Hz	Hertz (frequency)
DTK	Desired Track	IAF	Initial Approach Fix
EASA	European Aviation Safety Agency	IAS	Indicated Air Speed
EFD	Evolution Flight Display	IFR	Instrument Flight Rules
EFI	Electronic Flight Instrument	ILS	Instrument Landing System

IMC	Instrument Meteorological Conditions	LCD	Liquid Crystal Display
in Hg	Inches of Mercury	LDI	Lateral Deviation Indicator
Indicated	Information provided by properly calibrated and set instruments on the aircraft panel.	LOC	Localizer
IOP	Input/Output Processor	MAP	Main Application Processor
kHz	Kilohertz	mB	Millibars
KIAS	Knots Indicated Air Speed	MFD	Multi-Function Display
km	Kilometer	MHz	Megahertz
kt	Knots	MSG	Message
LAT	Latitude	MSL	Mean Sea Level
TACAN	Tactical Air Navigation System	NAVAID	Navigation Aid
TAS	True Air Speed	nm	Nautical Miles
TERM	Terminal Mode	NRST	Nearest
Track	Direction of aircraft movement relative to a ground position; also Ground Track'	OAT	Outside Air Temperature
TSO	Technical Standard Order	OBS	Omni-Bearing Selector
VAC	Volts, Alternating Current	PFD	Primary Flight Display
VDC	Volts, Direct Current	RMI	Radio Magnetic Indicator
VDI	Vertical Deviation Indicator	RSM	Remote Sensor Module
VFR	Visual Flight Rules	SDHC	Secure Digital High Capacity (microSDHC card)
VHF	Very High Frequency		
VLOC	VOR/Localizer		
VOR	VHF Omni-Directional Radio Range		

VORTAC	VHF Omni-Directional Radio Range and Tactical Air Navigation
VSI	Vertical Speed Indicator
WAAS	Wide Area Augmentation System
WPT	Waypoint

7.5. Index

Symbols

1/2, Hot Key	2-10
2/2, Hot Key	2-10
360/ARC, Hot Key	2-10 – 2-11

A

ADAHRS	4-2 – 4-7
Attitude	4-3
Free Gyro Mode	4-6 – 4-7
Heading	4-5 – 4-6
Pitot Obstruction Monitor	4-4
Advisory	6-20 – 6-21
Data Invalid or Unavailable	6-25
GPS Annunciations	6-21
GPSS Disabled	6-21
GPSS On	6-20
Navigation Source Invalid or Unavailable	6-21
REV Button Off	6-20
AHRS Reset, In-Flight	6-12
Perform	6-13
Aircraft Ownship Symbol	4-20

Air Data, Attitude and Heading Reference System	4-2 – 4-7	Attitude Fail	6-12, 6-18
<i>See also</i> ADAHRS		Attitude Indicators, Difference	6-6
Airspeed Indicator (Airspeed)	4-10 – 4-13	Auto Course	4-27
Airspeed	4-10	Disable	4-28
Bug	4-10	Enable	4-27
Bug, Set	3-12, 4-12	Select	2-28
Range	4-12	Autopilot Integration	4-33
Airspeed Display	4-13	Autopilot Operations, Typical	4-38
Tape	4-10 - 4-13	HDG Mode Operation - GPS Steering (GPSS	4-39
Hide/Display	4-13	HDG Mode Operation - Heading Bug Steering	4-39
Tape and Bug	2-24	NAV Mode Operation - GPS Navigation	4-40
Speed Markers	2-24	NAV Mode Operation - VLOC Navigation	4-39
Altimeter	4-14 – 4-18	B	
Altitude	4-14, 4-16 – 4-18	Barometer	2-3, 4-23
Bug	4-17	Barometric Pressure Adjustment	4-14
Bug, Set	4-17	Barometric Pressure, Set	3-8, 4-15
Caution	6-19	Barometric Pressure Setting Display	3-8, 4-19
Display	4-19	Barometric Units of Measure, Set	4-15
Tape	4-14	Battery	
Hide/Display	4-18	Countdown	6-16
Tape and Alerter	2-24	Operational	6-16
Altitude Display		Status, View	6-11
Attitude Indicator	2-23, 4-8 – 4-9	Nav Sources, Select	2-8
Analog Converter Unit	1-6	Source Select Buttons	2-8
Approvals	x	Brightness Control	5-10
ARC/360, Hot Key	2-11	<i>See also</i> Lighting	
Attitude Display	2-20 – 2-22, 4-8, 4-13	BRT ADJUST	2-16
Airspeed Indicator	4-10 – 4-13	BRT AUTO	2-16
Altimeter	4-14 – 4-16	Buttons	xv
Attitude Indicator	4-8		
Components	2-21		

C	
Cautions	6-18 – 6-19
Attitude Degraded	6-19
Check Pitot Heat	6-18
Cross Check Attitude	6-18
GPS Integrity Flag	6-19
GPS Invalid	6-19
GPSS Source Lost/Changed	6-19
CDI	
Course, Select	4-26, 4-28
Navigation Source	4-25
Radio Mode, GPS	4-32
Radio Source, VHF	4-32
Select	3-2, 4-31
Nav Source Select Button	2-8
Selected Course	4-26
Source Information Block	4-20
Source Label	4-26
Source Select Button	4-26
Check Pitot Heat	6-18
CHECK PITOT HEAT	4-4, 4-11, 6-2
Cleaning the Display Screen	2-19
Color Philosophy	xvi
Compass	4-21
360° Compass Mode	4-21
ARC CDI Compass Mode, Select	4-21
ARC Compass Mode	4-21
Compass Scale	4-22
Compass Type, Select	4-22
Modes: 360° vs. ARC	2-26
Select	3-16
Configuration Module	1-5
Configuring V-speeds	5-5 – 5-9
Controls	
Knobs	2-4 – 2-8
Left Knob Functions	2-4 – 2-5
Right Knob Functions	2-4 – 2-5
SYNC Function	2-6 – 2-7
Controls and Display	2-1 – 2-32
Controls	2-4 – 2-17
Elements	2-2 – 2-3
Conventions	xiv
Color Philosophy	xvi
Covered Functionality	xiv
Example Graphics	xviii
Information Covered in this Pilot's Guide	xix
Pilot Familiarity	xviii
Terminology	xiv
Warnings, Cautions, Notes	xvii
Copyrights, Trademarks and Patents	ix
Course Deviation Indicator and Scale	4-25
Course Pointer	4-23
Course Pointer and Deviation Indicator	4-32
Covered Functionality	xvii
CROSS CHECK ATTITUDE	4-3, 6-7, 6-20
CRS	2-5 – 2-8
Customizing the EFI	5-1 – 5-20

D		G	
Data Bar	2-27, 4-20	GENERAL SETTINGS A	5-1
Databases.....	1-8, 7-3	GENERAL SETTINGS B	5-2
Data Invalid or Unavailable	6-25	GPS	
Deviation		Annunciations	6-23
Indicator	4-23	Failures	6-11
Off Scale Indication	2-32	Integrity Flag	6-21
Scale	4-23	Invalid	6-21
Direction Indicator Fail	6-18	GPSS	
Direction Indicator (Magnetic Compass)	2-29 – 2-30, 4-23	Disable	6-17
Display	1-5, 2-19 – 2-35	Enable/Disable	4-46
Attitude Display	2-21	Engage	3-20
Cleaning the Display Screen	2-20	Hot Key	2-11
Lighting	2-17	Operation, Annunciations, and Autopilot Modes	6-16
Document Revisions	iv	Source Lost/Changed	6-22
		Wings Level	6-17
E		Ground Speed	4-21
Electrical Power, Loss of Aircraft	6-9	Ground Track Marker	2-31
Emergency and Abnormal Procedures	6-1 – 6-25		
Pitot/Static System Blockage	6-2 – 6-6	H	
Evolution Flight Display (EFD) system	1-1	Heading	4-23
Dual Display	1-2	Display	4-37
Single Display	1-2	Heading and Heading Bug	4-36
System Overview	1-4	Heading Bug, Set	2-8, 3-9, 4-36
Example Graphics	xxi	Hot Keys	xviii, 2-10
External Voltage Status, View	6-12		
Extreme Pitch	6-19	I	
		IAS	2-5 – 2-8
F		Information Covered in this Pilot's Guide	xvii
Flight Plan	4-41	Initial Flap Extension Speed Marker	4-10
Free Gyro Mode	4-6	Internal Battery Status, View	6-13
		Introduction	1-1 – 1-3

K

Knobs	
Left Knob Functions	2-5
Right Knob Functions	2-5
SYNC Function	2-6 – 2-7
SYNC Function, Perform	2-6
Using the Knobs (Example)	2-8

M

MENU	2-13 – 2-16
Brightness Control	2-14
Menu Text	2-15
Overview	5-1 – 5-11
GENERAL SETTINGS A	5-1
GENERAL SETTINGS B	5-2
POWER SETTINGS	5-10
SYSTEM STATUS	5-11
VSPEEDS A	5-6
VSPEEDS B	5-6
Page graphical bar	2-14
Page Name	2-14
Page number and mode	2-14
Using the Menus	2-13 – 2-16
Access and Navigate	2-15
Edit Menu Items	2-16
MEMS	4-2
Menu Keys	xviii
Micro Electro-Mechanical Systems	4-2
MicroSD Card	1-8, 7-7

N

Navigation	
Information	2-31
Source	4-23
Source Invalid or Unavailable	6-25
Source Select Buttons	2-9 – 2-10
Navigation Display	2-28, 4-23
Aircraft Heading Display	4-37
Auto Course	4-34
Auto Course Select	2-32
CDI Navigation Source	4-30
CDI Selected Course	4-35
Compass	4-24
Components	2-27
Course Deviation Indicator and Scale	4-25
Course Pointer	4-23
Course Pointer and Deviation Indicator	2-30
Deviation Off Scale Indication	2-30
Direction Indicator (Magnetic Compass)	2-28
Ground Track Marker	2-29,
Heading and Heading Bug	4-36
Rate of Turn Indicator	2-31, 4-30
TO/FROM Indicator	4-24
Vertical Speed Indicator	2-32
Navigation Source	
Select Buttons	
CDI Nav Source Select Button	2-8
NRM, Hot Key	2-10
Numerical Airspeed Value	4-10
Numerical Altitude Value	4-14

O		
Operating Limitations	7-1	Specifications
		7-3 – 7-4
		Analog Converter Unit
		7-5
		Operational
		7-6
		Remote Sensor Module
		7-5
P		Speed Bands
Pilot Familiarity	xviii	4-10
Pitch Scale	4-9	Ranges
Pitot and/or Static System Failures, Identifying	6-3, 6-4	5-7
Pitot Obstruction Monitor	4-4	Speed Markers
Pitot/Static System Blockage	6-2	2-23, 4-10
Suspected	6-3	Startup Splash Screen
Power On Manually	6-8	3-6
Power Override	6-11	SYNC Function
		2-4 – 2-6
		System Architecture
		1-3
		System Overview
		1-3 – 1-6
R		T
Range Button	2-17	Terminology
Rate of Turn Indicator	2-31, 4-20, 4-30	xiv
Rear Connections	1-4	Buttons
Remote Sensor Module	1-6	xv
REV Button	2-17, 6-7	Hot Keys
Off	6-20	xv
Right Knob Functions	2-5 – 2-6	Knobs
Roll Scale	4-8 – 4-9	xv
		Menu Keys
		xv
		TO/FROM Indicators
		4-20, 4-24
		Track Marker
		4-20, 4-31
S		U
Shutdown Procedure	6-7	Unit Serial Number, View
Single Display	1-2	7-2
Slip/Skip Indicator	4-9	Using the Menus
Software Versions	7-1 – 7-2	2-12
Input/Output Processor Software Version, View	7-2	V
Main Application Processor Software Version, View	7-1	Vertical Speed Indicator
		2-26, 4-32
		Voltage Status, View
		6-11

Vspeeds	4-10
Configuring	5-5 – 5-9
Definitions	5-5 – 5-6
Initial Flap Extension	5-6
Textual Labels, Enable	5-8
Textual Vspeed Labels, Set	5-9

W

Warning, Caution, and Advisory Summary	6-16 – 6-21
Warnings	6-16 – 6-17
Attitude Fail	6-16
Battery Countdown	6-16
Battery Operational	6-16
Direction Indicator Fail	6-16
Explained	xvii
Extreme Pitch	6-17
Warranty	xi
Card	xii
Conditions	xi
Dealer	xiii
Exclusions	xi
Exclusive	xii
Extension of	xiii
Incidental Damages	xii
Invalidation	xii
Limitation of Liability	xii
Procedure	xiii
Remedy	xi
Transportation Costs	xiii



Aspen Avionics, Inc.

5001 Indian School Road NE

Albuquerque, NM 87110

Phone: 888-99ASPEN (888-992-7736)

Phone, International: (505) 856-5034

Fax: (505) 314-5440

info@aspenavionics.com

www.aspenavionics.com